

Goulds 3700i

API 610 12th Edition

API OH2 Overhung, Single Stage, Radially Split



3700i

Proven API Leadership

Complete API Offering

- Over 20,000 units installed
- Over 3,000 between bearing pumps installed
- 40+ years of API expertise

Global Coverage

ITT Goulds Pumps has the global coverage needed to serve multi-national companies in any region.

Industry Leading Hydraulic Coverage

- We offer extensive coverage to meet your process needs.
- Better hydraulic fits can mean improved efficiency and long-term reliability and parts life.



8000 HP / 6000 kW Testing Capability

- Our expanded test facility can test your pump in the most demanding conditions.
- Testing at rated speeds is critical to access the impact of dynamic conditions including vibration.
- Testing of complete string can also be performed to check the compatibility of the drive unit.

API Engineering Expertise

- We package engineered pumps to meet your demanding applications — that fully conform to the latest API specifications.
- Engineered Packaging with a wide range of drivers, seals, piping, nozzle conformance, flanges, baseplates and QC testing.
- ITT is a world leader in technology and engineering, including hydraulics, materials science, mechanical design and fluid dynamics.





Model 3700

End Suction API 610/ISO 13709 Process Pump

- Designed for optimum reliability
- State-of-the-art mechanical design features
- 54 casing sizes and choice of impellers with most casings



Model 3700 on high-temperature service at a U.S. Gulf Coast refinery.



Gold Tailings Pumps in Australia - 3700 4x6-19

High-Temperature and Pressure Process Pumps That Meet or Exceed API 610 12th Edition

Safety, reliability and versatility are the key words for our end-suction, centerline-mounted, overhung (OH-2) API 610 process pump.

Safety and Reliability

We provide engineered solutions with true conformance to the latest API specifications including the stringent emissions containment per API 682. The result is a safe and rugged overhung API process pump designed for a minimum 20-year life.

Serviceability

- Capacity to 8,500 GPM (1930 m³/h)
- Total dynamic head to 1,200 feet (360 m)
- Temperature to 800° F (425° C)
- Pressure to 870 PSIG (60 bar)

Materials: Available in a wide range of materials including all API 610 constructions and custom application needs.

Engineered Hydraulics: An industry-leading 135 hydraulic combinations to better match your process for efficiency and reliability. Custom hydraulics are available.

Engineered Packaging with a wide range of drivers, seals, piping, nozzle configurations, flanges, baseplates and QC testing.

Applications

Column reflux, hot oil, stabilizer overhead, column bottoms, reboiler, stripper overhead, column charge, reactor feed, heat transfer, injection, tower bottoms, slop gas oil, fuel blending, heavy gas oil, scrubber circulation, offsite hydrocarbon transfer

3700i

Standard Features for Optimum Reliability

- **Proven API 610 Nozzle-Load Design**
Rugged casing and baseplate/pedestal support system provides flange-loading capability exceeding API 610 requirements without the use of a bearing frame support.
- **Full Flange Rating Pressure Capability**
All pumps designed to operate at two pole running speeds have casings designed for the full pressure capability of a 300 RF flange.
- **Spiral-Wound Casing Gasket**
Casing to cover joint sealed with a spiral-wound, controlled-compression gasket required by API 610. Provides positive sealing up to the maximum design pressure and temperature.



Improved Bearing Environment

- Innovative bearing frame design provides optimum heat dissipation.
- Condition-monitoring sites allow easy and consistent monitoring of temperature and vibration. Provision for instrumentation mounting per API 670 standard.
- Large oil sight glass allows viewing of the condition and level of oil, critical for bearing life.
- Extra-large oil sump means cooler-running bearings.
- Proven channeled oil lubrication system ensures flow-through of cooled oil to thrust and radial bearings.
- Oil Filter keeps the oil free of debris and moisture
- Standard dual oil rings, positively located, provide oil flow to channeled oil lubrication system and prevent oil foaming.



Patented Filters

Bearing oil contamination often discussed as black oil, caused by wind-blown sand and dust together with atmospheric moisture are major contributors to bearings failing well before their design life. In an industry first, all self-contained bearing housings include a cartridge filter assembly that will help safeguard the bearing oil from debris contamination.

The patent pending filter cartridge will also continuously work to scrub water from the bearing oil utilizing specifically engineered moisture absorbing materials built into the filter.

Oil with Particulate**



Run time = 72 hrs*	Run time = 314 hrs*
Black Oil	Result: Clean Oil

Oil with Water



Run time = 0 hrs*	Run time = 72 hrs*
Cloudy Oil	Result: Clean Oil

*Continuous operation at 3100RPM

**Test dust used is ISO 12103-1, A3 Medium test dust

The design allows for easy changeover of filter cartridges even while the pump is operating – no need to stop your process. All this additional reliability is achieved *without* the need for additional oil pumps or piping – no additional system complexity, monitoring or control overhead.



You change the oil and filter in your car, and it doesn't have a sight glass

- Black oil caused by debris and moisture contaminating the oil.
- Multi-functional filter assembly captures oil and circulates down through filter and liquid absorbing beads.
- Filter captures debris and beads absorb any water that may be present.
- New bearing housings designed so oil is thrown by oil ring to trough that leads to the oil filter assembly.

Typical oil change interval was every 3 months. That is extended to every 6 months with the filter. Pump doesn't need to be stopped in order to change the filter.



Optional Features for Application Flexibility

Goolds offers a range of options to meet specific plant and process requirements.

High-Temperature Capability

For high-temperature applications, these options are available:

Heat Flinger

Heat flinger dissipates shaft-conducted heat and circulates air to reduce heat buildup.



Air Cooling

High-capacity fan and shroud mounted on power end effectively reduce bearing frame temperature for cooler-running bearings without using cooling water.



Water Cooling

Finned cooler for maintaining oil/bearing temperature. Corrosion-resistant material.



Inducer Option

Lubrication Flexibility

Oil Mist Lubrication System

Connections for pure or purge oil mist lubrication can be provided for immediate use or future requirements. A simple plug change to toggle between systems.



Sealed Power End

Designed with magnetic end face seals and expansion chamber to prevent contaminants from entering the power end.

Lubricant Sight Glass and Sampling Bottle

For visual inspection and sampling of oil.



Other Options

Extra-Wide Baseplate

Provided for seal systems with auxiliary components to improve maintenance access.

Heavy-Duty Pedestal

Unique trapezoidal design provides superior resistance to deflections from flange loads.

Top Suction Nozzle

This option reduces space requirements and installation costs for unique applications.

Inducer Option

Under certain conditions, reduction in NPHSR can be provided with an axial flow inducer.

Coke-Crusher Option

Allows coke particles to be easily pumped by crushing coke with a cutter screw.

Upgrade Your Older-Style API Process Pump

Goulds PRO Services® Centers are experienced with reconditioning all types of pumps and rotating equipment, restoring equipment to original specifications.

Customers rely on PRO Services Centers for economical repair versus replacement, decreased downtime, reduced inventory of replacement parts and the advantage of updated engineering technology.



Profit from these exclusive quality services:

- Quality rebuilds/repairs ensure maximum reliability from your rotating equipment.
- One-year warranty on all rebuilds/repairs.
- Upgrade old designs to latest technology to maximize reliability.
- Add oil filter to OH Frame

Your local PRO Services Center offers solutions for lowering total cost of ownership of your pumping systems. This can be achieved by upgrading your older-style API process pumps to today's high-performance API standard.

The question of whether to replace or upgrade existing equipment is a challenge faced by most end users today. When casing, piping and foundation are in good shape, upgrading your existing pump to comply with current API standards usually is more economical than new pump installation. By exploring all options, a better decision can be made.

Upgrades may involve hydraulic modifications, drop-in replacements and/or power end conversions. PRO Services Centers are experienced with all pump manufacturers.



Model 3700 With Diesel Engine Driver

3700i

API 610 12th Edition

API OH2 Overhung, Single Stage, Radially Split

DUAL VOLUTE CASING

Standard on 3-inch discharge and larger. Minimizes radial load and reduces shaft deflection for increased mechanical seal life.

TANGENTIAL DISCHARGE DESIGN

Maximizes hydraulic efficiency.

CONFINED CONTROLLED-COMPRESSION GASKET

Spiral-wound gasket assures positive sealing with no chance of misalignment.

RENEWABLE WEAR RINGS STANDARD ON ALL SIZES

Positively locked and set screwed. Front and rear rings control seal chamber flows and pressures. Optional non-metallic rings for improved efficiency.

IMPELLER

Multiple closed impellers for most casings to meet specific hydraulic requirements. Balanced to stringent ISO 1940 Grade 2.5

NOZZLE LOAD CAPABILITY

Casing/baseplate design optimized to exceed toughest API nozzle load criteria.

INTERGRAL FLANGES

Both vent and drain flanges are cast features instead of welded features for increased flexibility.

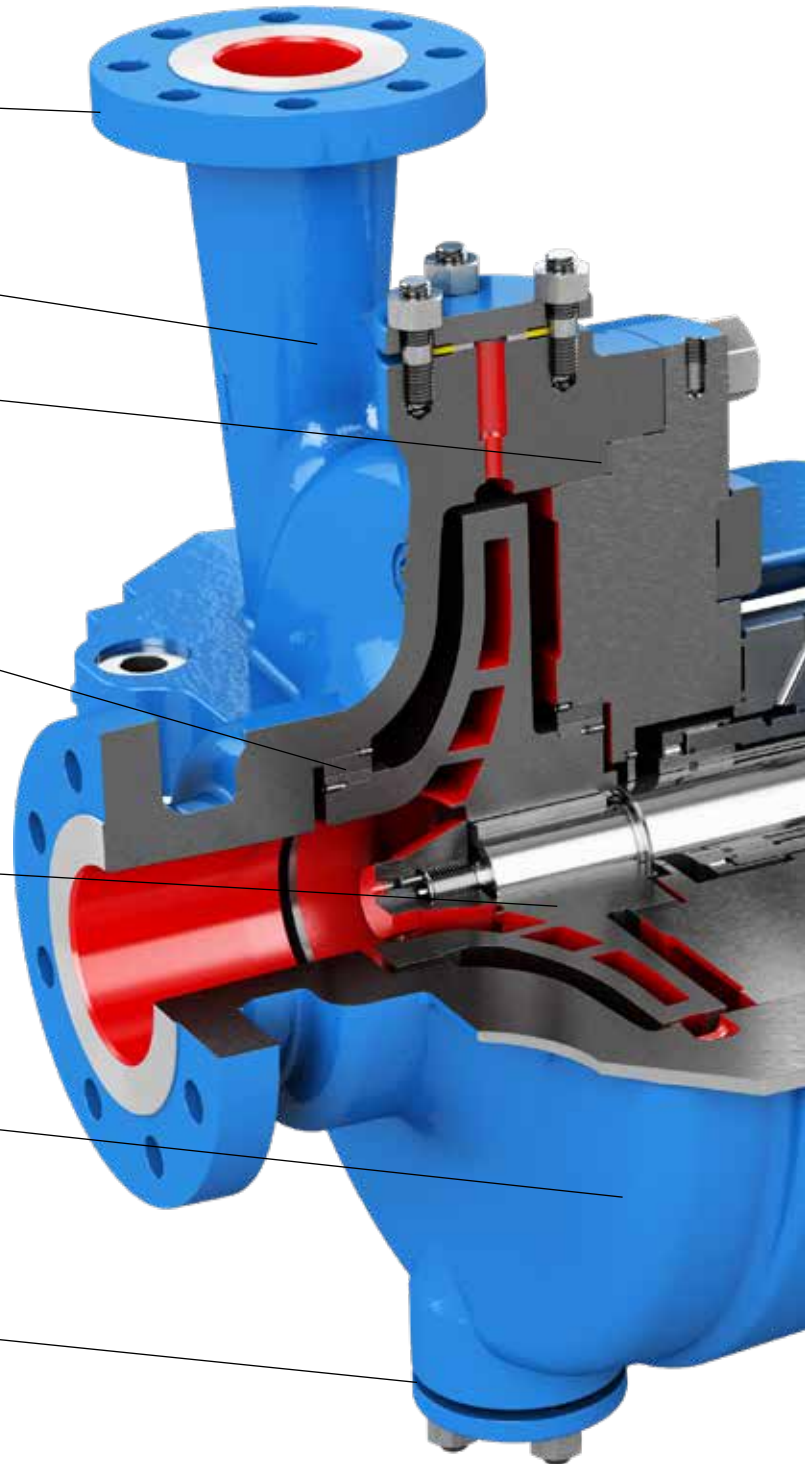

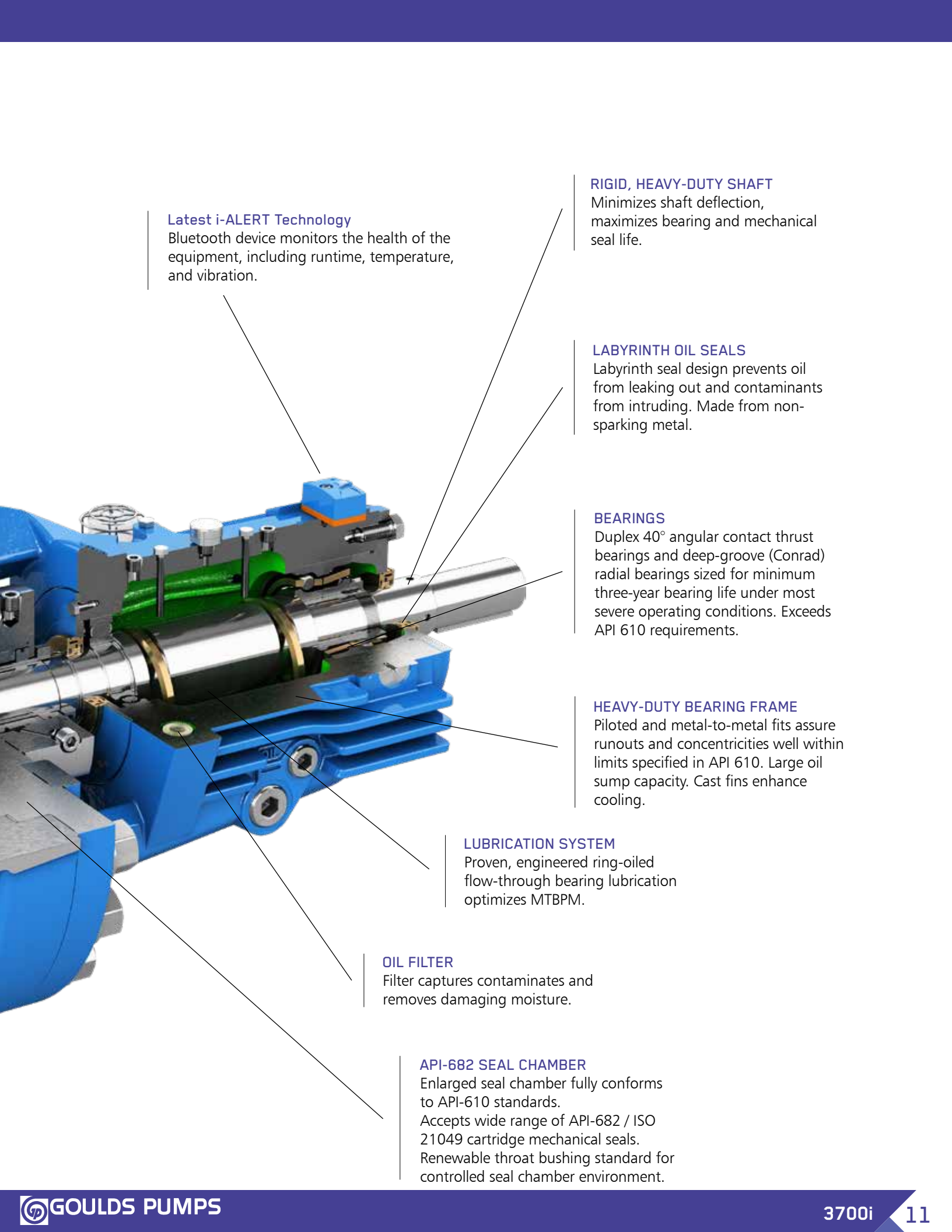

Latest i-ALERT Technology

Bluetooth device monitors the health of the equipment, including runtime, temperature, and vibration.

RIGID, HEAVY-DUTY SHAFT

Minimizes shaft deflection, maximizes bearing and mechanical seal life.

LABYRINTH OIL SEALS

Labyrinth seal design prevents oil from leaking out and contaminants from intruding. Made from non-sparking metal.

BEARINGS

Duplex 40° angular contact thrust bearings and deep-groove (Conrad) radial bearings sized for minimum three-year bearing life under most severe operating conditions. Exceeds API 610 requirements.

HEAVY-DUTY BEARING FRAME

Piloted and metal-to-metal fits assure runouts and concentricities well within limits specified in API 610. Large oil sump capacity. Cast fins enhance cooling.

LUBRICATION SYSTEM

Proven, engineered ring-oiled flow-through bearing lubrication optimizes MTBPM.

OIL FILTER

Filter captures contaminants and removes damaging moisture.

API-682 SEAL CHAMBER

Enlarged seal chamber fully conforms to API-610 standards. Accepts wide range of API-682 / ISO 21049 cartridge mechanical seals. Renewable throat bushing standard for controlled seal chamber environment.

3700i

Hydraulic Coverage

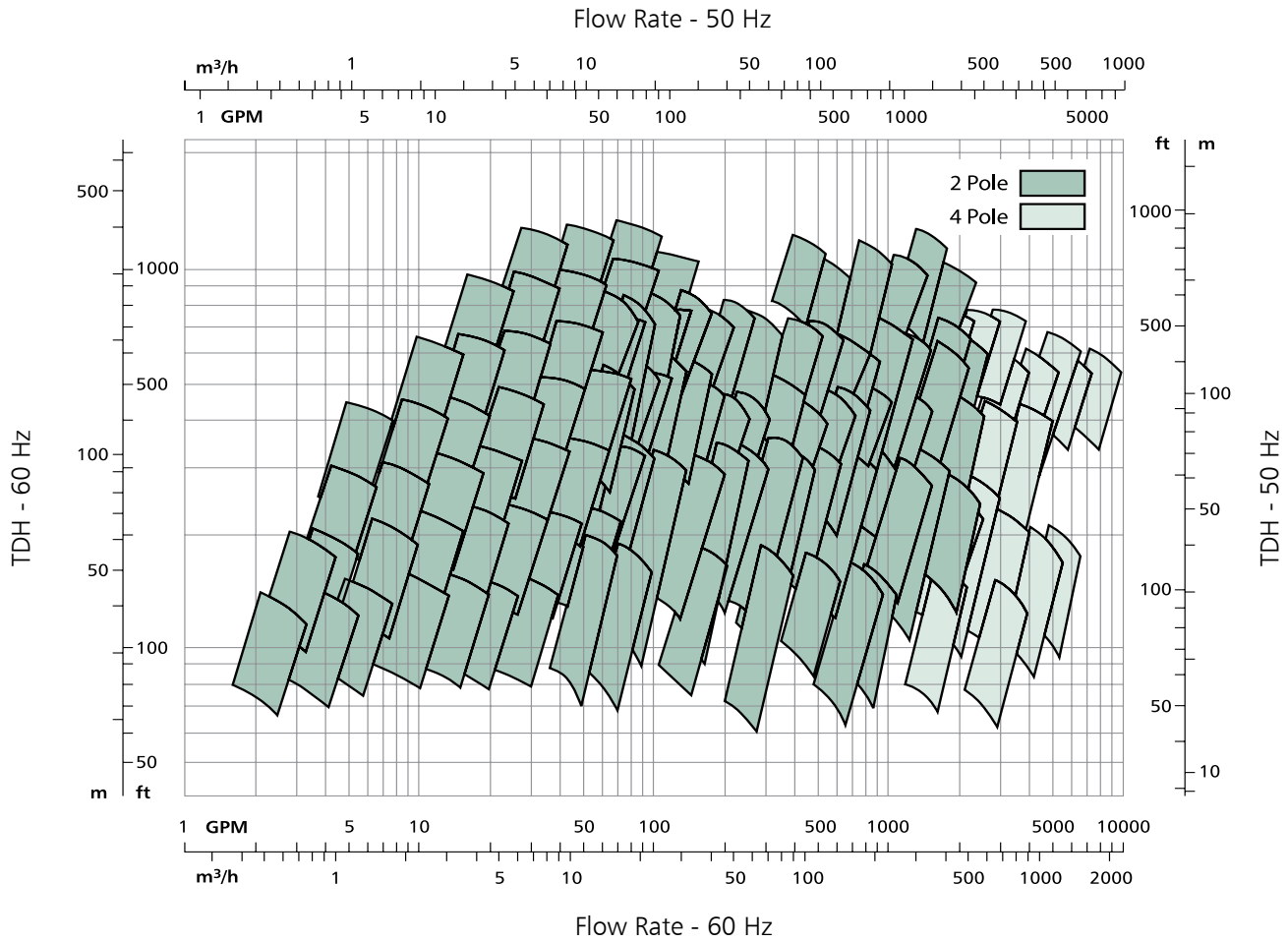

Typical 3700 Installation

Sectional View

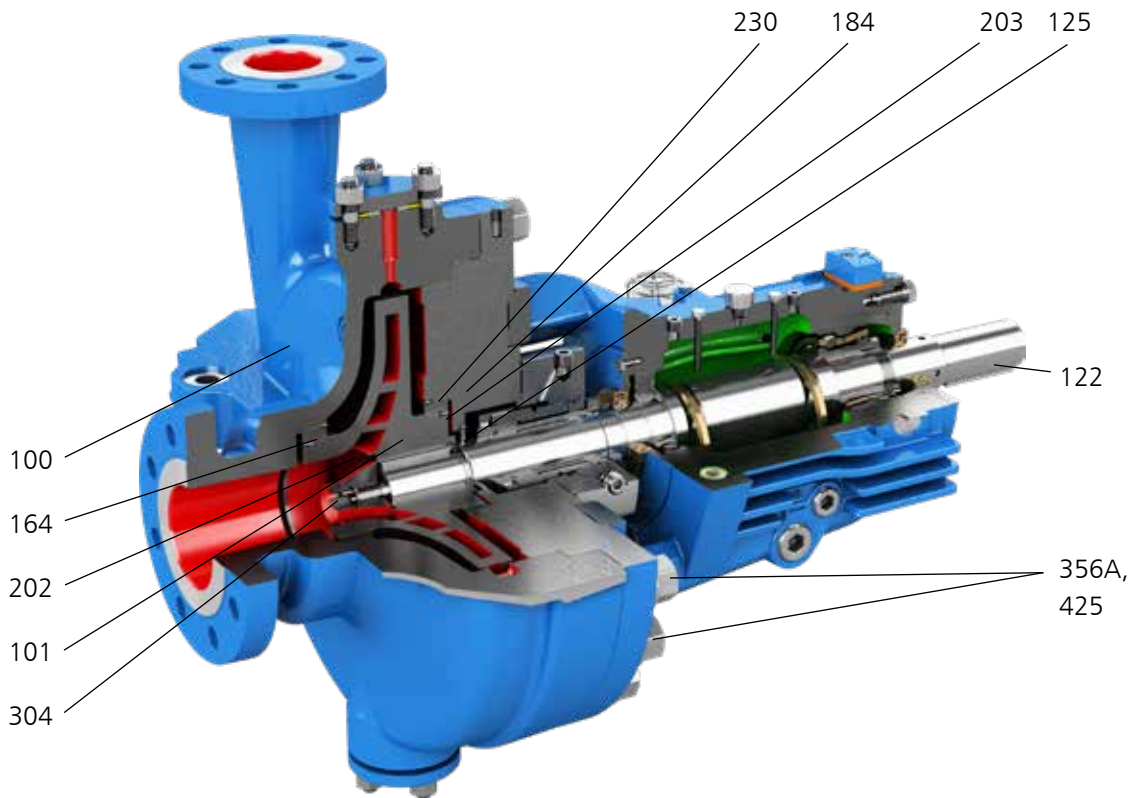

Parts List and Materials of Construction

Item	Part Name	S-4	S-5	S-6	S-8	C-6	A-8	D-1	D-2
100	Casing	Carbon Steel				12% Chrome	316L SS	Duplex SS	S. Duplex SS
101	Impeller	Carbon Steel		12% Chrome	316L SS	12% Chrome	316L SS	Duplex SS	S. Duplex SS
122	Shaft	ANSI 4140 *			316L SS	410 SS	316L SS	Duplex SS	S. Duplex SS
125	Throat Bushing	Cast Iron	410 SS		316L SS	410 SS	316L SS	Duplex SS	S. Duplex SS
164, 230	Wear Ring - Casing	Cast Iron	12% Chrome		Hardfaced 316L SS	12% Chrome	Hardfaced 316L SS	Hardfaced Duplex SS	Hardfaced S Duplex SS
202, 203	Wear Ring - Impeller	Cast Iron	12% Chrome		Hardfaced 316L SS	12% Chrome	Hardfaced 316L SS	Hardfaced Duplex SS	Hardfaced S Duplex SS
184	Seal Chamber Cover	Carbon Steel				12% Chrome	316 SS	Duplex SS	S. Duplex SS
304	Impeller Nut	Steel	Nitronic 60	Nitronic 60				Duplex SS	S. Duplex SS
356A, 425	Casing Studs / Nuts	ANSI 4140							

* 410 SS on S-6 when temperature exceeds 350°F (175°C)

A Leader in API Engineered Pump Package Solutions

API Family of Pumps

Model 3700
OH-2

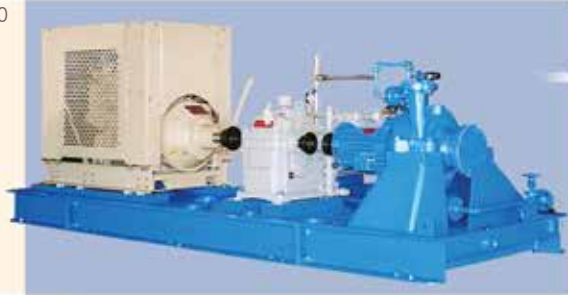

Model 3910
OH-3

Model 3620
3640
BB-2



Model 3610
BB-1



API Type	Goulds Model	Capacity GPM (M ³ /Hour)	TDH Feet (Meters)	Temperature °F(°C)	Pressure PSIG (kg/cm ²)
OH-2	3700i	8500 (1930)	1200 (360)	800 (425)	870 (60)
OH-3	3910	6000 (1360)	750 (230)	650 (340)	600 (42)
BB-1	3610	50000 (11355)	700 (215)	300 (150)	300 (21)
BB-2	3640i	7500 (1700)	2500 (760)	850 (455)	1130 (75)
BB-2	3620i	20000 (4540)	1500 (455)	850 (455)	1000 (70)
BB-3	3600	8500 (1930)	9000 (2740)	400 (205)	4000 (275)
BB-5	7200SB	4000 (910)	9000 (2740)	800 (425)	4000 (275)
VS4	API 3171	3180 (720)	525 (160)	450 (232)	750 (50)
VS1	VIT	70000 (14760)	3500 (1060)	500 (260)	2500 (175)
VS6	VIC	70000 (14760)	3500 (1060)	500 (260)	2500 (175)
VS6	VICR	2800 (636)	4500 (1372)	500 (260)	2500 (175)



Model 3600
BB-3



Model 7200SB
BB-5



Model VICR
VS6



Model API 3171
VS4



Model VIC-T
VS6

Locations



For more information Please Visit:
www.gouldspumps.com | www.ittproservices.com



— An ITT Brand

240 Fall Street
Seneca Falls, NY 13148
Phone: 315.568.2811
Fax: 315.568.2418
www.gouldspumps.com

© 2021 ITT Goulds Pumps Inc.

B.3700i.en-US.2021-02