

TECHNICAL DATASHEET



EF COUPLER

01 Update - 11/2016

TECHNICAL DATA

Article No	101 117 2160 0032
d (mm)	32
D (mm)	43
Z (mm)	77
m (mm)	18
Weight (Kg)	0,06
Box Quantity (pcs)	75
Box Dimension (cm)	29x48x22

INJECTION MOULDED

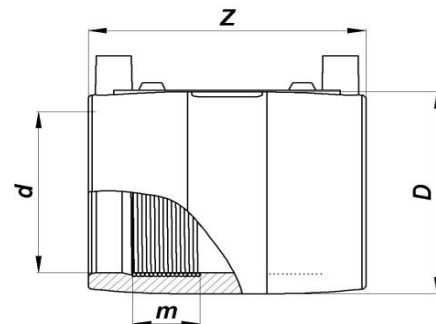

IDENTIFICATION OF PRODUCT

D(mm)	32
SDR	11
RAW MATERIAL	PE 100
PRESSURE CLASS	16 Bar Water 10 Bar Gas
TRADEMARK	NTG
EXECUTION	Injection Moulded
STANDARD	EN 12201-3 EN 1555-3 AS / NZS 4129
SPECIFICATION	Suitable for SDR11 pipe Removable center stopper 4 mm pin connectors

EF SPECIFICATION

WELDING VOLTAGE	40 V
RESISTANCE	6.76 Ω
WELDING TIME	45 Sec
COOLING TIME	3 Min
WINDING TYPE	Monofilar
WELDING BARCODE	



Tolerance on diameters and thickness according to the standards. The other dimensions are specialized. Tolerance $\pm 5\%$. NTG PLASTIK reserves all the right to change any information without giving prior notice. The production, distribution and utilization of this document without explicit authorization is prohibited.