

Product description



Customer  
Customer no.  
Contact  
Care of

Project  
Project no.

Page  
Date

1 / 2  
2023-09-25

Pos.n	Qty.	Item no.	Description	UP / EUR	TP / EUR
<b>8 Premium high-efficiency heating circulation pumps</b>					
8.1	1	7000001852	<p>Centrifugal pump: PrimAX 25-6 130 RED T2</p> <p>Biral Heat circulation pump PrimAX 25-6 130 RED T2 Inkl. thermal insulation shells, Biral Connector and angled connector EEL ; 1x230V</p> <p>High-efficiency built in pipe pump with permanent magnet motor for feeding hot water according to VDI 2035, with continuous speed control for: -Proportional pressure pp -Constant pressure cp -Constant speed cs</p> <p>Feed medium : Water Feed height : Feed volume : Media temperature min. : + 2°C Media temperature max. : + 110°C</p> <p>Ambient temperature : 0 - 40°C Max. operating pressure : 10 bar Diameter nominal : DN Installation lenght : 130 mm Flange connection : G 1 1/2" Rohranschluss : Rp 1"</p> <p>Voltage : 230 V Frequency : 50 / 60 Hz Motor input : 0,003 kW...0,034 kW Nominal current : 0,03 A...0,27 A Type of protection : IP X4D Insulation class : F (155°C) Motor protection : Integrated</p> <p>Pump casing : grey cast iron Impeller : PES 30%GF</p> <p>-Power input display -Flow rate display (m³/h) -Flow indicator -Button lock -Operating status display -Fault display</p> <p>Gross weight : 1,8 kg</p>	Price on req.	Price on req.

**Total Price**      **Price on req.**

Customer  
Customer no.  
Contact  
Care of

Project  
Project no.  
Position 8  
Location

Page 2 / 2  
Date 2023-09-25

**PrimAX 25-6 130 RED T2** 7000001852  
Premium high-efficiency heating circulation pumps

**Requested data**

Flow  
Head  
Fluid Water  
Temperature 20 °C  
Working pressure 1.000 kPa

**Operating data**

Flow  
Head  
Permitted working pressure  
Min. fluid temperature 2 °C  
Max. fluid temperature 110 °C

**Required working pressure**

Values are valid for hot water,  
Altitude 500m above sea level.  
Changing of required working pressure at +/- 0.01bar  
per +/- 100m altitude above sea level.

75 °C	90 °C	110 °C
5 kPa	28 kPa	108 kPa

**Pump data**

Installation dimension	130 mm
Rated voltage	1~230 V 50 Hz
Rated current	0,27 A
Leistungsaufnahme P1	0,050 kW
Insulation class	F
Degree of protection	IP X4D
Weight	1,8 kg

**Short-circuit-proof motor doesn't  
required overload protection.**

**Materials**

Pump casing	Cast iron
Impeller	PES
Can	Stainless steel
Dichtung	EPDM
slide bearing	Ceramic
Shaft	Ceramic

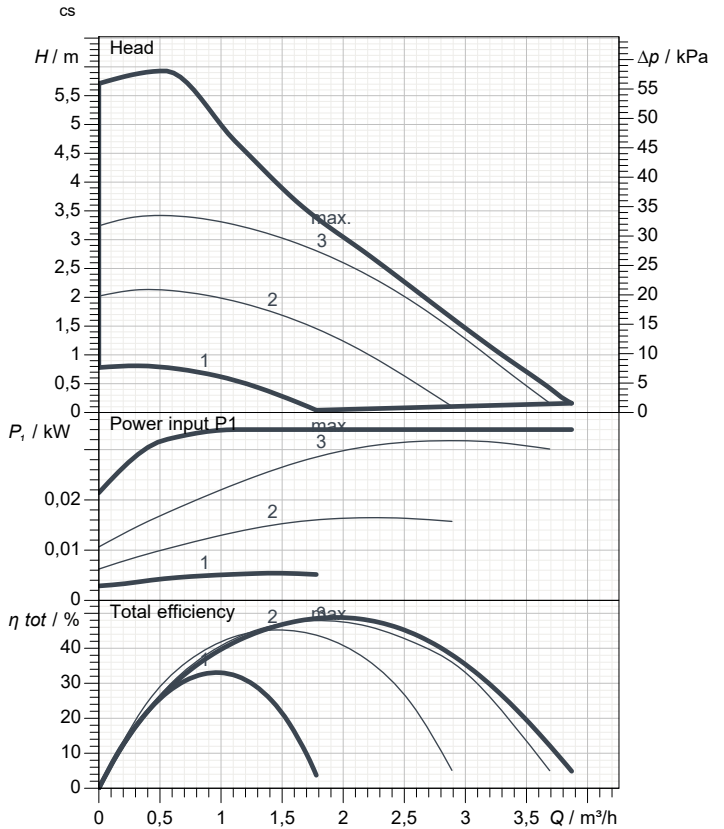
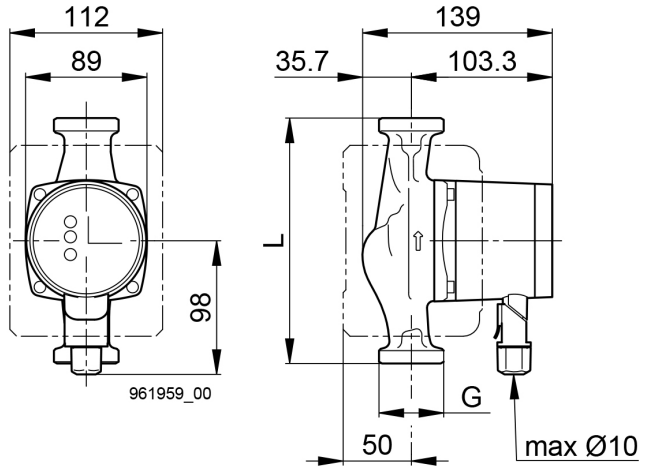

**Electrical connection**

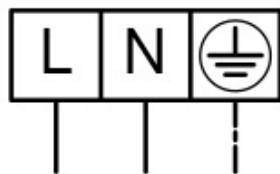

L, PE, N Power supply

AC in  
~1x230V ± 10%  
50/60 Hz

961958\_00

Remarks: