

Product description



Customer
Customer no.
Contact
Care of

Project
Project no.

Page 1 / 2
Date 2023-09-26

Pos.n	Qty.	Item no.	Description	UP / EUR	TP / EUR
6 Premium high-efficiency heating circulation pumps					
6.1	1	NBT2021120	<p>Centrifugal pump: Modula 32F-12 220 RED noBT/T2 M</p> <p>Biral Heat circulation pump Modula 32F-12 220 RED noBT/T2 M without Bluetooth Connect Inkl. thermal insulation shells EEI <=0,20; 1x230V</p> <p>High-efficiency built in pipe pump with permanent magnet motor for feeding hot water according to VDI 2035, with continuous speed control for: -Proportional pressure pp -Constant pressure cp -Constant speed cs</p> <p>Feed medium : Water Feed height : Feed volume : Medium temperature : 15 °C...110 °C</p> <p>Ambient temperature : 0 - 40°C Max. operating pressure : 1.600 kPa Diameter nominal : DN 32 Installation lenght : 220 mm Flange connection : PN 6/16</p> <p>Voltage : 1~230 V Frequency : 50 / 60 Hz Motor input : 0,015 kW...0,329 kW Nominal current : 0,17 A...1,51 A Type of protection : IP X4D Insulation class : F (155°C) Motor protection :Integrated</p> <p>Pump casing : grey cast iron Impeller : PES 30%GF</p> <p>-Fault or status message (switchable) -External OFF/ON (switchable) -Power Limit (can be activated) -Operating status display</p> <p>Gross weight : 15,3</p> <p>Available as option: - BIM Biral Interface Module - Kit for recessed installation of electronics</p>	Price on req.	Price on req.

Total Price **Price on req.**

Customer
Customer no.
Contact
Care of

Project
Project no.
Position 6
Location

Page 2 / 2
Date 2023-09-26

Modula 32F-12 220 RED noBT/T. NBT2021120
Premium high-efficiency heating circulation pumps

Requested data

Flow
Head
Fluid **Water**
Temperature **20 °C**
Working pressure **1.000 kPa**

Operating data

Flow
Head
Power input P1
Permitted working pressure **1.600 kPa**
Min. fluid temperature **15 °C**
Max. fluid temperature **110 °C**

Required working pressure

Values are valid for hot water,
Altitude 500m above sea level.
Changing of required working pressure at +/- 0.01bar
per +/- 100m altitude above sea level.

75 °C	95 °C	110 °C
92 kPa	132 kPa	192 kPa

Pump data

Installation dimension **220 mm**
Rated voltage **1~230 V 50 Hz**
Rated current
Leistungsaufnahme P1 **0,850 kW**
Insulation class **F**
Degree of protection **IP X4D**
Weight **15,3 kg**

**Short-circuit-proof motor doesn't
required overload protection.**

Materials

Pump casing	Cast iron
Impeller	PES
Can	PPS
Dichtung	EPDM
slide bearing	Ceramic
Shaft	Stainless steel

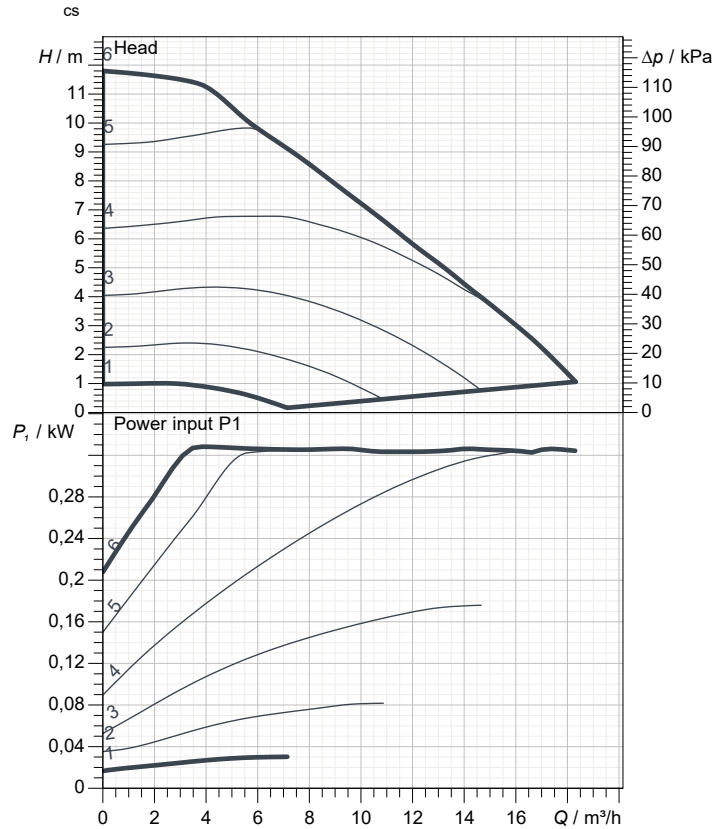
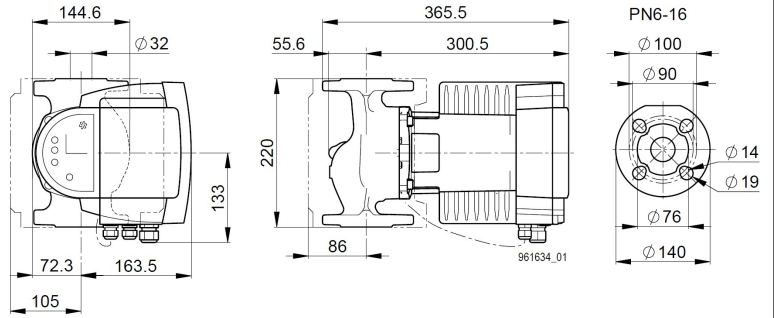

Electrical connection

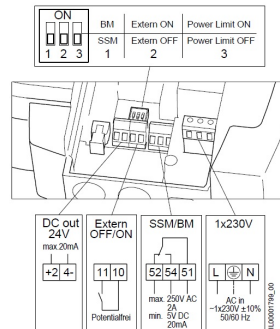

Remarks: