



Leading in water supply

PP-R/PP-RCT Piping Systems

Pipes, fittings, valves, unions,
cutting tools, welding equipment,
welding devices and more



Contact information

Germany

Address

Kessel Wassertechnologie GmbH
Auweg 3
35647 Waldsolms-Brandoberndorf

Sales department

Tel. +49 (0)60 85 / 9868-410
Fax +49 (0)60 85 / 9868-420
info@k-aqua.de · www.k-aqua.de

Quality /Technical support

support@k-aqua.de



Applying new strategies - our

Leading in water supply

The business field of Kessel Wassertechnologie GmbH is manufacturing pipes and fittings for water supply in several plastic materials which positions the company in the construction value chain as a construction material supplier and manufacturer.

With the premium manufacturer KESSEL – Leading in drainage – it exists a close and long partnership. With this experience of decades we will transport our success to the future.



Kessel Wassertechnologie GmbH, Waldsolms-Brandoberndorf, Germany

experience is your advantage



Leading in drainage

The name of KESSEL has stood for the drainage of buildings and premises for more than 50 years. This knowledge, collected over decades, is not just flowing continuously into product development, but also into our customer service. This is how we can help you to open up new markets and to extend existing business sectors.

The company, which started in 1963 as a small sub-contracting company for the plastics processing industry, is now an international company with more than 450 employees active in the drainage sector in Germany, Europe and Asia. The intention of providing technical perfection and long-standing partnership with our customers has made us the market leader.



KESSEL AG Lenting, Germany

K-Aqua- Impressions

Kessel Wassertechnologie GmbH is a company with people working very efficient and autonomous for the goal to find the best market-oriented solutions for their customers.

We achieve at all times a balance of customer, business and employee benefits by all of our products, systems and processes. This is our very own key to long-term market success.

Our urge to improve processes and products constantly ensures the economic quality of our work and our existence.

Taking responsibility and market-oriented attitude of each of us is reflected in the quality of our work, our products and our togetherness. Openness to other cultures and languages, other products, markets and businesses, new ideas, technologies and organizations, partners and new collaborations is the reality of our being.

Comprehensive, cross-border thinking is common to all of us and is systematically encouraged!

Our organizational structure is consistently adapted to the needs of the market. Process chains are formed by the value chain of customers' requirements



KESSEL AG-References

Over the past decades, KESSEL products have proven themselves countless times in destinations all over the world. The following references quickly mirror the extensive installation possibilities which KESSEL products offer.

Fairmont Hotel, Dubai
DC - Towers, Austria
Airport, Schiphol (Netherlands)
Atlantis Resorts Hotel, Dubai
Beijing Beichen Century Center & Hotel, China



PP-R/PP-RCT Pipes & Fittings

The drainage specialist - why KESSEL has earned this title

There is a reason that our aims are entitled „Everything for drainage“. This is because we concentrate on what we do best: integrated solutions for the drainage of building and property from one source - KESSEL. In other words, you can be sure that we will find the right solution for your drainage problem.

KESSEL product lines offer solutions for residential housing as well as commercial buildings and underground construction: the range includes backwater protection devices, drains for interior or exterior installation, pumps / lifting stations, grease and fuel separators, inspection chambers, rainwater management systems and surface drainage products. For unique customer requirements, KESSEL has created a custom project department staffed by engineers and computer draftsmen to develop and design solutions for all your needs.

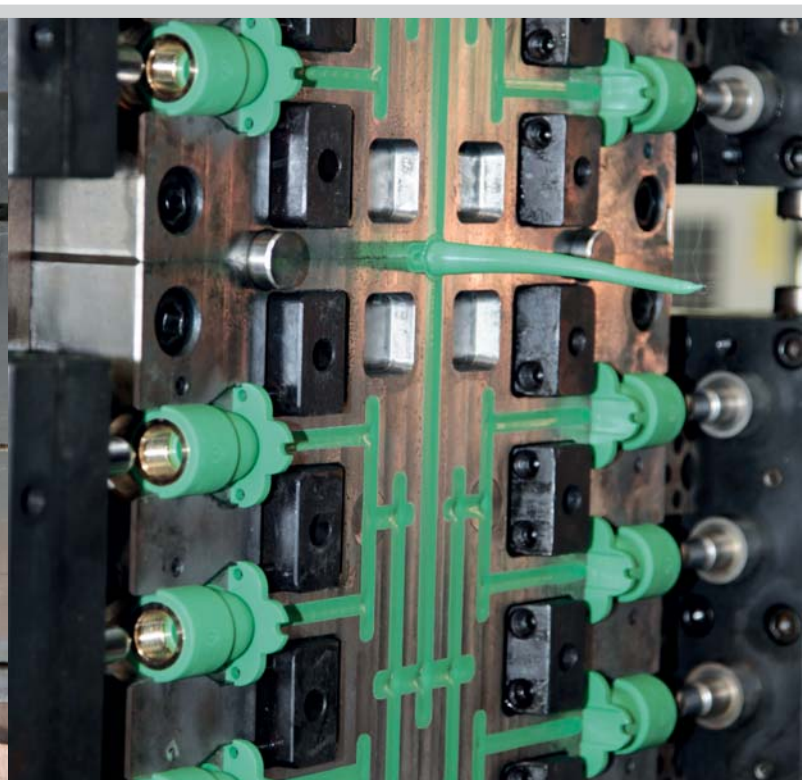

for drinkable hot & cold water

The K-Aqua PP-R/PP-RCT piping system includes different types of pipes (mono layer and multilayer reinforced pipes with glass fiber) with several wall types in SDR 6, SDR 7,4, SDR 9 and SDR 11. Depending of the pipe type the available dimensions starts from size 20 mm up to 250 mm. The fittings are available in sizes 20 mm up to 250 mm as well as complementary products like valves, unions, cutting tools, welding equipment, welding devices, and more...



Pipes

Page 67



Fittings

Page 73



Transition Fittings

Page 83



Valves

Page 93



Tools

Page 101

K-Aqua-Leading in water supply



 **K-Aqua**
Kessel Wassertechnologie GmbH



Index

Page

1 Features	13 - 31
2 Quality assurance	33 - 37
3 Welding	39 - 46
4 Installation	47 - 59
5 Storage	61 - 63
6 Products	65 - 105





1 Features

Page

1.1 The scope	15
1.2 Chemical resistance	15
1.3 Resistance to current strays	15
1.4 Soundproofness	15
1.5 Low thermal conductivity	15
1.6 Low pressure loss	15
1.7 No-toxicity	15
1.8 Easy workability	15
1.9 UV resistance	16
1.10 Cracking resistance under stress	16
1.11 Advantages of the K-Aqua piping system	16
1.12 Material properties PP-R	16 - 21
1.13 Material properties PP-RCT	22 - 27
1.14 Table of chemical resistance PP	28 - 30
1.15 Material properties transition parts	31



Environmentally-friendly

Before polypropylene was invented, the gaseous waste from oil such as propylene and ethylene were simply burned, because they were useless. Today, these gases are used to produce polypropylene, thus drastically reducing atmospheric pollution. The production process also eliminates the potential pollution of rivers, streams and lakes, due to the use of water in a closed cooling cycle.



Recyclable

Polypropylene is commonly recycled, and has the number „5“ as its resin identification code, allowing efficient separation of different polymer types for recycling the raw material. The recycled raw materials have to meet the manufacturing requirements of the environment commission, which stipulate that there is a minimum use of natural resources, reduced emissions, a long working life-span and optimum re-use. We recycle all production waste and cut-offs, noting that there is a high demand for polypropylene for recycling purposes as it can be recycled.



Superior

Polypropylene (PP), also known as polypropene, is a thermoplastic polymer used in a wide variety of applications, it is unusually resistant to many chemical solvents, bases and acids. This allows polypropylene to be used as an engineering plastic. Polypropylene is most commonly used for plastic moldings: it is injected into a mold while molten, forming complex shapes at relatively low cost and high volume, such as pipes and fittings.



Durable

Polypropylene products last much longer than those made from most similar materials. They are easy to wipe clean, hard wearing and withstand aging and extreme temperatures. Being more durable than alternative materials, products made from polypropylene don't need to be replaced as often, which means saving cost, resources, our environment and our future.

K-Aqua is designed for hot and cold water application and it is the latest and most suitable system for all plumbing applications. Besides plumbing, also it can be used for a variety of applications like air distribution, radiator heating, etc. The specific chemical structure of **K-Aqua** provides well balanced mechanical properties and superior long term heat resistance, ensuring the water flowing through which does not have any negative biological effect.

1.1 The Scope

K-Aqua products offer a superior German quality piping system, that could be equally installed in the residential and the industrial field:

- Sanitary applications.
- Heating & air-conditioning systems.
- Compressed air installations.
- Watering systems for greenhouses and gardens.
- Transporting liquid material.

For calculating the resistance, lifespan and safety of the **K-Aqua** system, depending on the average working temperature:

PN 20	10 bar	70° C
-------	--------	-------

The **K-Aqua** system should last for a minimum of 50 years. **K-Aqua** is an excellent choice for piping of clean hot & cold water.

- Potable water application
- Heating system construction
- Climate technology
- Chilled water technology
- Swimming-pool technology
- Chemical transport due to high chemical resistance
- Rainwater application
- Irrigation
- Compressed air systems
- Under- floor- heating- systems
- Application in the field of ship building
- Agriculture

1.2 Chemical Resistance

K-Aqua is a polyolefin polymer that features a high molecular weight. Therefore, it is more resistant to chemicals such as: acid, lime or cement. See table of chemical resistance. The resistance of **K-Aqua** products which are not submitted to the following factors: mechanical stress, various fluids, 20, 60 and 100° C temperatures according to ISO TR10358:1993.

1.3 Resistance to Current Strays

Like most thermoplastic products, **K-Aqua** is a poor electrical conductor. Therefore, there is no risk of stray currents occurring.

1.4 Soundproofness

The elasticity of **K-Aqua** pipes makes it viable to absorb and eliminate almost all vibrations, that would normally occur in the traditional cast iron pipes. Therefore, **K-Aqua** is highly soundproof at no extra cost.

1.5 Low Thermal Conductivity

K-Aqua has a low thermal conductivity (0.24 W/ m.K) that reduces the heat dispersion of the fluid that it conveys. Also, it reduces the condensation, which normally forms on the outside of the generic metal pipes, under specific hygrometric conditions.

1.6 Low Pressure Loss

The inside surface of **K-Aqua** is sleek, smooth with very few irregularities (0.0070 μ), which convey a significant reduction in pressure loss. As result, limestone cannot build up inside the pipe.

1.7 No-Toxicity

The raw material used for the production of **K-Aqua** is absolutely non-toxic and complies with the most up-to-date national and international regulations.

1.8 Easy Workability



One of the major attractions of the **K-Aqua** system is that it is extremely light and easy to weld and install. Our pipes with diameters ranging from 20 mm to 250 mm are extremely simple to assemble, providing the suitable polyfusion device. (See chapter 3)

1.9 UV Resistance

K-Fiber UV Pipes black cooled pipes are UV-resistant but must not be installed without protection in an exposed area. **K-Aqua** pipes and fittings are equipped with a stabilizer which allows for safe transport and installation. However, they should not be stored for more than six months in the open air.

1.10 Cracking Resistance Under Stress

The values determining the time resistance capacity of the **K-Aqua** system are the following:

- Mechanical stress = Pressure 
- Thermal strain = Temperature 
- Stress duration = Time 

The relationship between the above parameters can be controlled through regression curves.

K-Aqua minimum resistance values have been determined through internal pressure tests, at various temperature intervals: 20, 40, 60, 80, 95, 110° C. A logarithmic graphic representation shows the comparative tensions, the lifetime (in years), and the regression curves at various temperatures according to the DIN 8078 standard. See figure page 17 and 23

1.11 Advantages of the K-Aqua Piping System

K-Aqua provides all the necessary parts, for a complete and easy installation, from the beginning to the end. Saying goodbye to the conventional problems of the past. It is guaranteed to feel and see the difference with the **K-Aqua** piping system.

- **K-Aqua** is manufactured with superior German quality.
- **K-Aqua** made of corrosion resistant material, putting an end to old corrosion complications.
- Enjoy some serenity and peacefulness with **K-Aqua** because it is not as noisy as metal pipes.
- Unlike the alternatives, **K-Aqua** is made of opaque polypropylene, which is a nonpolluting material, preventing algae from growing.
- **K-Aqua** is completely recyclable, with no risk of air pollution, making it an environmentally friendly system.

1.12 Material Properties PP-R

Table 1: Physical properties PP-R

Property	Typical	Value	Test Method
Density	905	kg/m ³	ISO 1183
Melt Flow Rate (230° C / 2.16 kg)	0,25	g/10 min	ISO 1133
Flexural Modulus (2 mm/min)	800	MPa	ISO 178
Tensile Modulus (1 mm/min)	900	MPa	ISO 527
Tensile Strain at Yield (50 mm/min)	13,5	%	ISO 527-2
Tensile Strain at Yield (50 mm/min)	25	MPa	ISO 527-2
Thermal Conductivity	0,24	w/(m K)	DIN 52612
Coefficient of Thermal Expansion (0° C/70° C)	1,5*10E-4	1/K	DIN 53752
Charpy Impact Strength unnotched (23° C)	NO break		ISO 179/1eU
Charpy Impact Strength unnotched (0° C)	NO break		ISO 179/1eU
Charpy Impact Strength unnotched (-20° C)	40	kJ/m ²	ISO 179/1eU
Charpy Impact Strength notched (23° C)	20	kJ/m ²	ISO 179/1eA
Charpy Impact Strength notched (0° C)	3,5	kJ/m ²	ISO 179/1eA
Charpy Impact Strength notched (-20° C)	2	kJ/m ²	ISO 179/1eA

Figure 1 - Reference curves for expected strength of PP-R

DIN EN ISO 15874-2:2013-06
EN ISO 15874-2:2013 (D/E)

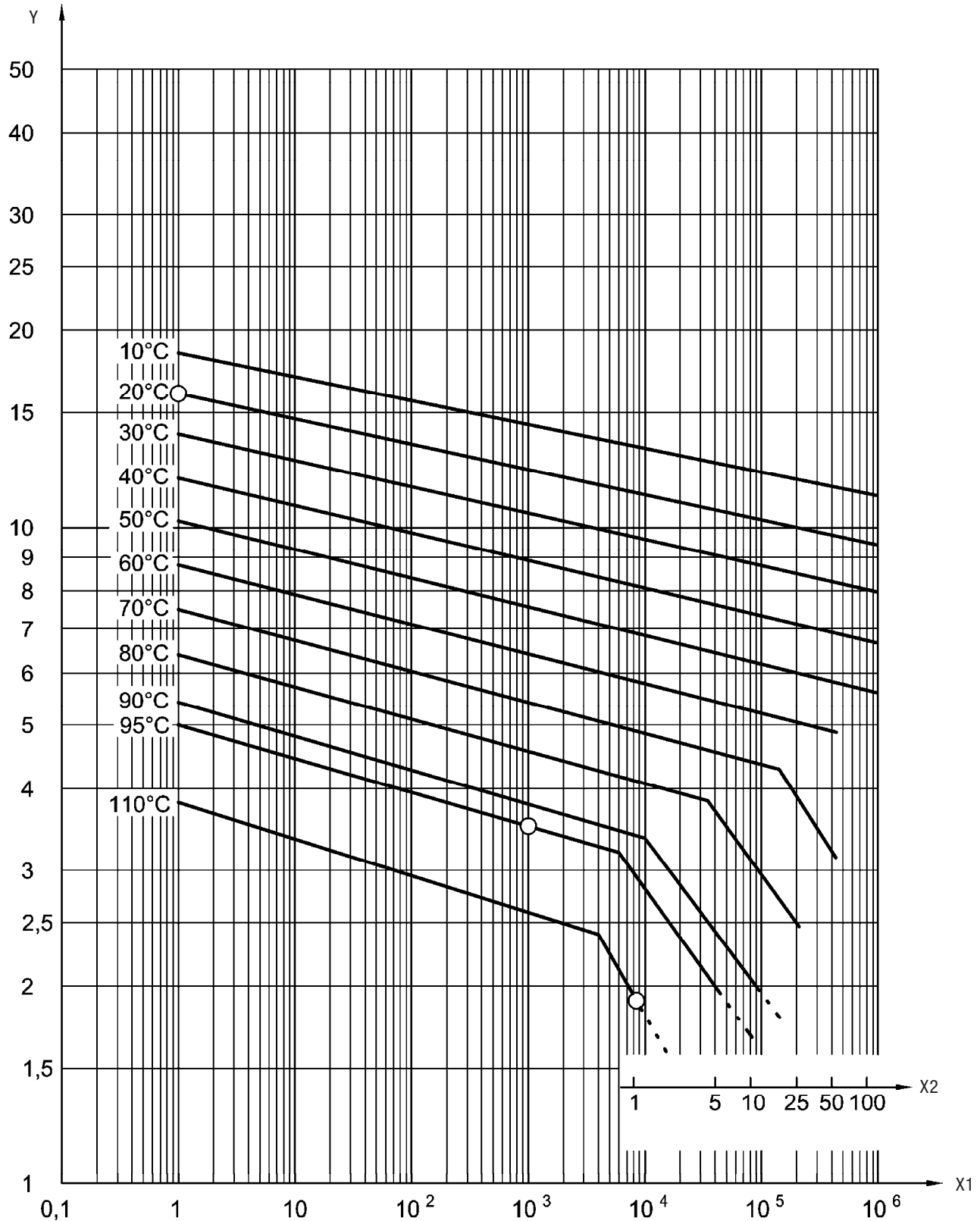

Key

X1 time, t_1 , to fracture, in hours

X2 time, t_2 , to fracture, in years

Y = hoopstress, α , in megapascal

Table 2 - Allowable operation pressures for PP-R pipes, conveying water
Safety factor (SF) = 1,25

DIN 8077:2008-09

Temperature °C	Years of service	Pipe series S									
		20	16	12,5	8,3	8	5	4	3,2	2,5	2
		Diameter/Wall thicknesses SDR									
		41	33	26	17,6	17	11	9	7,4	6	5
Allowable operation pressure bar											
10	1	5,3	6,6	8,4	12,6	13,3	21,1	26,5	33,4	42,1	53,0
	5	4,9	6,2	7,9	11,9	12,5	19,8	25,0	31,5	39,7	49,9
	10	4,8	6,1	7,7	11,6	12,2	19,3	24,4	30,7	38,6	48,7
	25	4,7	5,9	7,4	11,2	11,8	18,7	23,6	29,7	37,4	47,0
	50	4,5	5,7	7,2	10,9	11,5	18,2	23,0	28,9	36,4	45,9
	100	4,4	5,6	7,0	10,7	11,2	17,8	22,4	28,2	35,5	44,7
20	1	4,5	5,6	7,1	10,8	11,3	18,0	22,6	28,5	35,9	45,2
	5	4,2	5,3	6,7	10,1	10,6	16,9	21,3	26,8	33,7	42,5
	10	4,1	5,2	6,5	9,9	10,4	16,4	20,7	26,1	32,8	41,4
	25	3,9	5,0	6,3	9,5	10,0	15,9	20,0	25,2	31,7	39,9
	50	3,8	4,8	6,1	9,3	9,7	15,4	19,5	24,5	30,9	38,9
	100	3,7	4,7	6,0	9,0	9,5	15,0	18,9	23,9	30,1	37,8
30	1	3,8	4,8	6,1	9,2	9,6	15,3	19,2	24,2	30,5	38,5
	5	3,6	4,5	5,7	8,6	9,0	14,3	18,0	22,7	28,6	36,0
	10	3,5	4,4	5,5	8,4	8,8	13,9	17,5	22,1	27,8	35,0
	25	3,3	4,2	5,3	8,1	8,4	13,4	16,9	21,3	26,8	33,8
	50	3,2	4,1	5,2	7,8	8,2	13,0	16,4	20,7	26,1	32,9
	100	3,1	4,0	5,0	7,6	8,0	12,7	16,0	20,1	25,4	31,9
40	1	3,2	4,1	5,1	7,8	8,2	13,0	16,3	20,6	25,9	32,6
	5	3,0	3,8	4,8	7,3	7,6	12,1	15,3	19,2	24,2	30,5
	10	2,9	3,7	4,7	7,1	7,4	11,8	14,8	18,7	23,5	29,6
	25	2,8	3,5	4,5	6,8	7,1	11,3	14,3	18,0	22,6	28,5
	50	2,7	3,4	4,3	6,6	6,9	11,0	13,9	17,4	22,0	27,7
	100	2,6	3,3	4,2	6,4	6,7	10,7	13,5	16,9	21,4	26,9
50	1	2,7	3,4	4,3	6,6	6,9	11,0	13,8	17,4	21,9	27,6
	5	2,5	3,2	4,0	6,1	6,4	10,2	12,9	16,2	20,4	25,7
	10	2,5	3,1	3,9	5,9	6,2	9,9	12,5	15,7	19,8	25,0
	25	2,4	3,0	3,8	5,7	6,0	9,5	12,0	15,1	19,0	24,0
	50	2,3	2,9	3,6	5,5	5,8	9,2	11,6	14,7	18,5	23,3
	100	2,2	2,8	3,5	5,4	5,6	9,0	11,3	14,2	17,9	22,6

Temperature °C	Years of service	Pipe series S									
		20	16	12,5	8,3	8	5	4	3,2	2,5	2
		Diameter/Wall thicknesses SDR									
		41	33	26	17,6	17	11	9	7,4	6	5
Allowable operation pressure bar											
60	1	2,3	2,9	3,6	5,5	5,8	9,2	11,6	14,7	18,5	23,3
	5	2,1	2,7	3,4	5,1	5,4	8,6	10,8	13,6	17,2	21,6
	10	2,1	2,6	3,3	5,0	5,2	8,3	10,5	13,2	16,6	21,0
	25	2,0	2,5	3,1	4,8	5,0	8,0	10,1	12,7	16,0	20,1
	50	1,9	2,4	3,0	4,6	4,9	7,7	9,7	12,3	15,5	19,5
70	1	1,9	2,4	3,1	4,6	4,9	7,8	9,8	12,3	15,5	19,6
	5	1,8	2,2	2,8	4,3	4,5	7,2	9,1	11,4	14,4	18,1
	10	1,7	2,2	2,7	4,2	4,4	7,0	8,8	11,1	13,9	17,5
	25	1,5	1,9	2,4	3,6	3,8	6,0	7,6	9,6	12,1	15,2
	50	1,2	1,6	2,0	3,0	3,2	5,1	6,4	8,1	10,2	12,8
80	1	1,6	2,0	2,6	3,9	4,1	6,5	8,2	10,3	13,0	16,4
	5	1,4	1,8	2,3	3,4	3,6	5,7	7,2	9,1	11,5	14,5
	10	1,2	1,5	1,9	2,9	3,0	4,8	6,1	7,7	9,7	12,2
	25	0,9	1,2	1,5	2,3	2,4	3,9	4,9	6,2	7,8	9,8
95	1	1,1	1,4	1,8	2,7	2,9	4,6	5,8	7,3	9,2	11,6
	5	0,7	0,9	1,2	1,8	1,9	3,1	3,9	4,9	6,2	7,8
	(10) ^a	(0,6)	(0,8)	(1,0)	(1,5)	(1,6)	(2,6)	(3,3)	(4,1)	(5,2)	(6,6)

^{a)} The values between parentheses apply in cases where it can be demonstrated that the test was carried out for more than a year at 110° C

Table 3 - Allowable operation pressures for PP-R pipes, conveying water
Safety factor (SF) = 1,5

DIN 8077:2008-09

Temperature °C	Years of service	Pipe series S									
		20	16	12,5	8,3	8	5	4	3,2	2,5	2
		Diameter/Wall thicknesses SDR									
		41	33	26	17,6	17	11	9	7,4	6	5
Allowable operation pressure bar											
10	1	4,4	5,5	7,0	10,5	11,1	17,5	22,1	27,8	35,1	44,1
	5	4,1	5,2	6,6	9,9	10,4	16,5	20,8	26,2	33,0	41,6
	10	4,0	5,1	6,4	9,7	10,1	16,1	20,3	25,6	32,2	40,5
	25	3,9	4,9	6,2	9,3	9,8	15,6	19,6	24,7	31,1	39,2
	50	3,8	4,8	6,0	9,1	9,6	15,2	19,1	24,1	30,3	38,2
	100	3,7	4,6	5,9	8,9	9,3	14,8	18,6	23,5	29,6	37,2
20	1	3,7	4,7	5,9	9,0	9,4	15,0	18,8	23,7	29,9	37,7
	5	3,5	4,4	5,6	8,4	8,9	14,1	17,7	22,3	28,1	35,4
	10	3,4	4,3	5,4	8,2	8,6	13,7	17,2	21,7	27,4	34,5
	25	3,3	4,1	5,2	7,9	8,3	13,2	16,6	21,0	26,4	33,3
	50	3,2	4,0	5,1	7,7	8,1	12,9	16,2	20,4	25,7	32,4
	100	3,1	3,9	5,0	7,5	7,9	12,5	15,8	19,9	25,0	31,5
30	1	3,2	4,0	5,0	7,6	8,0	12,7	16,0	20,2	25,4	32,0
	5	3,0	3,7	4,7	7,2	7,5	11,9	15,0	18,9	23,8	30,0
	10	2,9	3,6	4,6	7,0	7,3	11,6	14,6	18,4	23,2	29,2
	25	2,8	3,5	4,4	6,7	7,0	11,2	14,1	17,7	22,3	28,1
	50	2,7	3,4	4,3	6,5	6,8	10,9	13,7	17,2	21,7	27,4
	100	2,6	3,3	4,2	6,3	6,6	10,6	13,3	16,8	21,1	26,6
40	1	2,7	3,4	4,3	6,5	6,8	10,8	13,6	17,1	21,6	27,2
	5	2,5	3,2	4,0	6,0	6,3	10,1	12,7	16,0	20,2	25,4
	10	2,4	3,1	3,9	5,9	6,2	9,8	12,3	15,5	19,6	24,7
	25	2,3	2,9	3,7	5,6	5,9	9,4	11,9	15,0	18,8	23,7
	50	2,3	2,9	3,6	5,5	5,8	9,2	11,5	14,5	18,3	23,1
	100	2,2	2,8	3,5	5,3	5,6	8,9	11,2	14,1	17,8	22,4
50	1	2,3	2,8	3,6	5,5	5,7	9,1	11,5	14,5	18,2	23,0
	5	2,1	2,7	3,4	5,1	5,3	8,5	10,7	13,5	17,0	21,4
	10	2,0	2,6	3,3	4,9	5,2	8,2	10,4	13,1	16,5	20,8
	25	2,0	2,5	3,1	4,7	5,0	7,9	10,0	12,6	15,9	20,0
	50	1,9	2,4	3,0	4,6	4,8	7,7	9,7	12,2	15,4	19,4
	100	1,8	2,3	2,9	4,5	4,7	7,5	9,4	11,8	14,9	18,8

Temperature °C	Years of service	Pipe series S									
		20	16	12,5	8,3	8	5	4	3,2	2,5	2
		Diameter/Wall thicknesses SDR									
		41	33	26	17,6	17	11	9	7,4	6	5
Allowable operation pressure bar											
60	1	1,9	2,4	3,0	4,6	4,8	7,7	9,7	12,2	15,4	19,4
	5	1,8	2,2	2,8	4,3	4,5	7,1	9,0	11,3	14,3	18,0
	10	1,7	2,2	2,7	4,1	4,3	6,9	8,7	11,0	13,9	17,5
	25	1,6	2,1	2,6	4,0	4,2	6,6	8,4	10,5	13,3	16,7
	50	1,6	2,0	2,5	3,8	4,0	6,4	8,1	10,2	12,9	16,2
70	1	1,6	2,0	2,5	3,9	4,1	6,5	8,1	10,3	12,9	16,3
	5	1,5	1,9	2,4	3,6	3,8	6,0	7,5	9,5	12,0	15,1
	10	1,4	1,8	2,3	3,5	3,6	5,8	7,3	9,2	11,6	14,6
	25	1,2	1,5	2,0	3,0	3,1	5,0	6,3	8,0	10,0	12,7
	50	1,0	1,3	1,7	2,5	2,6	4,2	5,3	6,7	8,5	10,7
80	1	1,3	1,7	2,1	3,2	3,4	5,4	6,8	8,6	10,8	13,7
	5	1,2	1,5	1,9	2,9	3,0	4,8	6,0	7,6	9,6	12,1
	10	1,0	1,2	1,6	2,4	2,5	4,0	5,1	6,4	8,1	10,2
	25	0,8	1,0	1,2	1,9	2,0	3,2	4,1	5,1	6,5	8,1
95	1	0,9	1,2	1,5	2,3	2,4	3,8	4,8	6,1	7,6	9,6
	5	0,6	0,8	1,0	1,5	1,6	2,6	3,2	4,1	5,2	6,5
	(10) ^a	(0,5)	(0,6)	(0,8)	(1,3)	(1,3)	(2,2)	(2,7)	(3,4)	(4,3)	(5,5)

^{a)} The values between parentheses apply in cases where it can be demonstrated that the test was carried out for more than a year at 110° C

1.13 Material Properties PP-RCT

PP-RCT (Polypropylene-Random Crystallinity Temperature) is a material classification used to describe the second-generation class of PP-R materials. Introduced by Borealis in 2004 through its RA7050 range materials, it sets a milestone in the advancement of PP pressure piping systems. The pipe class has recently been included in EN ISO 15874, the global standard for plastics piping systems for hot and cold water pipe installations. PP-RCT is a polypropylene-random-copolymer with a special crystallinity which provides an improved pressure resistance, especially at elevated temperatures.

Pressure tests according to ISO 9080 on pipes manufactured from PP-RCT materials demonstrate 50 years service life at 70° C of 5 MPa, compared to the 3.2 MPa for standard PP-R materials. These very capabilities allow PP-RCT to increase performance and competitiveness for PP-R producers, and offer advantages for building designers and end-users alike.

Using PP-RCT in your pipe design will allow for increased performance vs. standard PP-R such as:

- increased pressure class with the same dimensioning
- higher hydraulic capacity with same outer diameter
- weight reduction (from 14 % up to 25 %) in pipe
- higher percentage of smaller pipes in actual installations (percentage depends upon specific design)
- cost efficient system due to beneficial dimensioning
- easier installation
- greater possibilities to tailor your heating PP-R pipe design
- opening up for special applications such as larger diameter mains for skysrise airconditioning systems
- weldable with known PP welding procedures
- fully established in domestic- as well as global standards incl. ISO and DIN

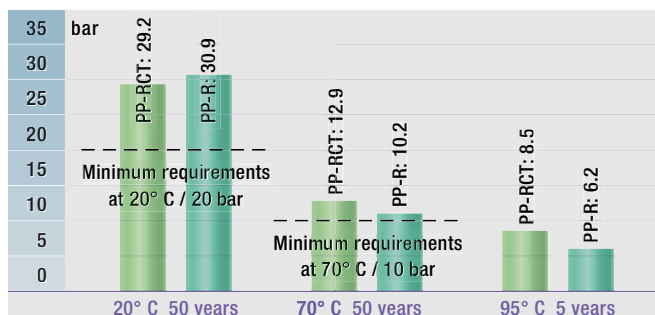

Higher pressure load through improved crystalline structure

With a special method of treatment of the material even smaller and more crystals are formed on the PP-RCT compared to PP-R. This means even more safety in permanent application because of higher pressure resistance at higher temperatures.

PP-R Pipes

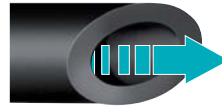

Higher flow

The reduced wall thickness leads to a higher flow rate at same and higher pressure load to increased flow rate.

PP-RCT Pipes



Higher stability at high temperatures

Through the special manufacturing of PP-RCT maximum working temperatures at higher pressure resistance were raised.

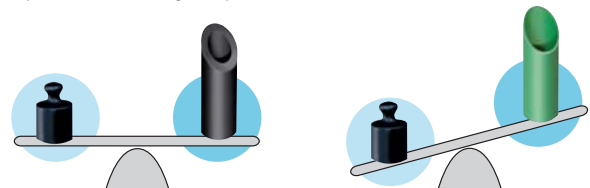

Lower weight

Through reduced wall thickness the weight of the PP-RCT pipes is considerably reduced.

Table 4: Physical properties PP-RCT

Property	Typical	Value	Test Method
Density	905	kg/m³	ISO 1183
Melt Flow Rate (230° C / 2.16 kg)	0,3	g/10 min	ISO 1133
Tensile Stress at Yield (50 mm/min)	25	MPa	ISO 527-2
Tensile Strain at Yield (50 mm/min)	10	%	ISO 527-2
Modulus of Elasticity in Tension (1 mm/min)	900	MPa	ISO 527
Charpy Impact Strength notched (+23° C)	40	kJ/m²	ISO 179/1eA
Charpy Impact Strength notched (0° C)	4	kJ/m²	ISO 179/1eA
Charpy Impact Strength notched (-20° C)	2	kJ/m²	ISO 179/1eA
Mean Linear Thermal Coefficient of Expansion from 0° C to 70° C	1,5	*10-4K-1	DIN 53752
Thermal Conductivity	0,24	WK-1m-1	DIN 52612 Part 1
Surface Resistance	> 1012	Ohm	DIN 53482/VDE 0303 Part 2

DIN EN ISO 15874-2:2013-06
EN ISO 15874-2:2013 (D/E)

Figure 2 - Reference curves for expected strength of PP-RCT

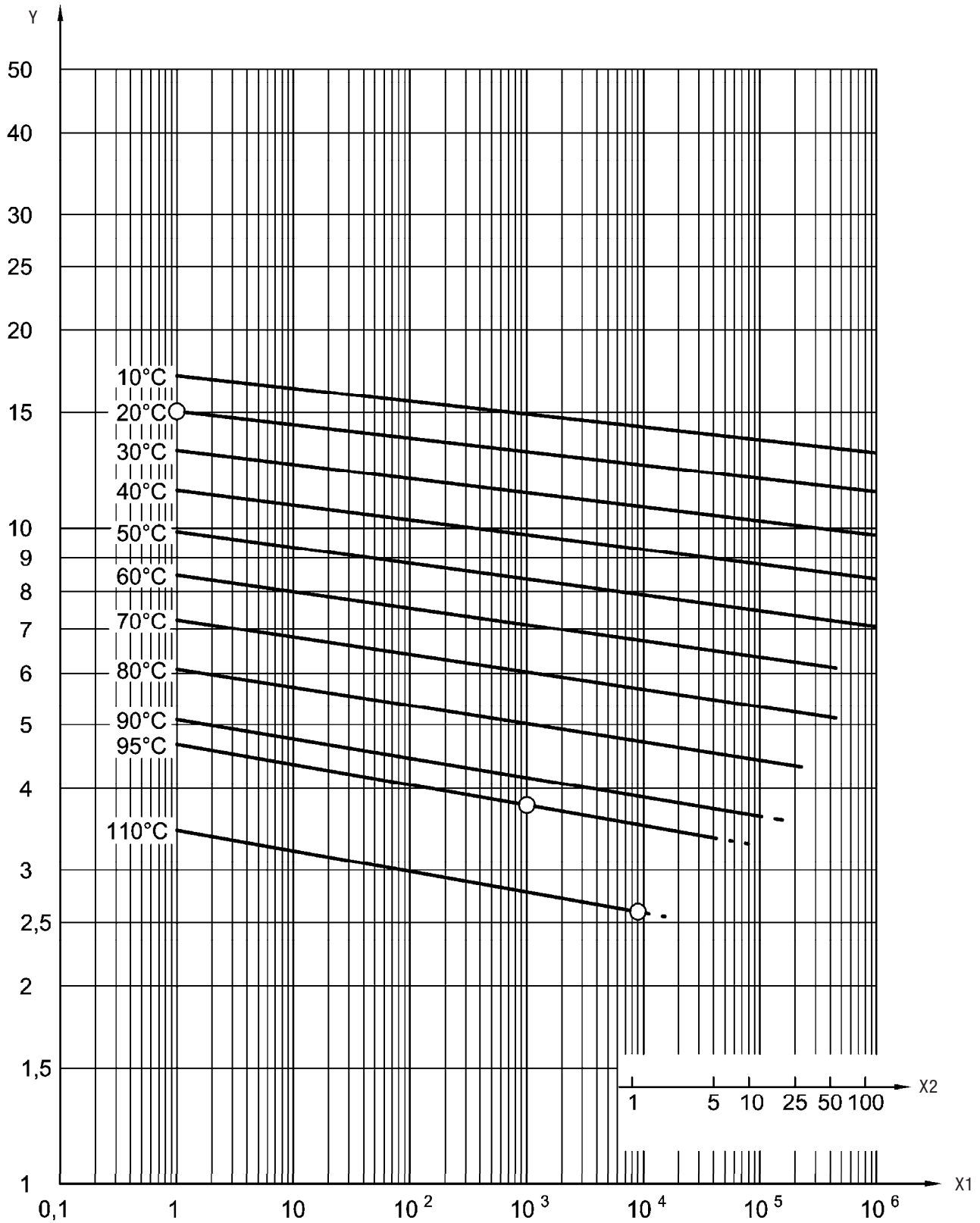

Key

X1 time, t_1 , to fracture, in hours

X2 time, t_2 , to fracture, in years

Y = hoopstress, α , in megapascal

Table 5 - Allowable operation pressures for PP-RCT, conveying water
Safety factor (SF) = 1,25

DIN 8077:2008-09

Temperature °C	Years of service	Pipe series S									
		20	16	12,5	8,3	8	5	4	3,2	2,5	2
		Diameter/Wall thicknesses SDR									
		41	33	26	17,6	17	11	9	7,4	6	5
Allowable operation pressure bar											
10	1	5,7	7,2	9,1	13,7	14,4	22,8	28,8	36,2	45,6	57,4
	5	5,5	7,0	8,8	13,3	14,0	22,1	27,9	35,1	44,2	55,7
	10	5,5	6,9	8,7	13,1	13,8	21,9	27,5	34,7	43,7	55,0
	25	5,4	6,8	8,5	12,9	13,5	21,5	27,1	34,1	42,9	54,0
	50	5,3	6,7	8,4	12,7	13,4	21,2	26,7	33,6	42,3	53,3
	100	5,2	6,6	8,3	12,6	13,2	20,9	26,3	33,2	41,8	52,6
20	1	5,0	6,3	7,9	11,9	12,5	19,9	25,0	31,5	39,7	50,0
	5	4,8	6,1	7,6	11,6	12,1	19,3	24,2	30,5	38,5	48,4
	10	4,7	6,0	7,5	11,4	12,0	19,0	23,9	30,1	37,9	47,8
	25	4,6	5,9	7,4	11,2	11,7	18,6	23,5	29,6	37,2	46,9
	50	4,6	5,8	7,3	11,0	11,6	18,4	23,1	29,2	36,7	46,2
	100	4,5	5,7	7,2	10,9	11,4	18,1	22,8	28,8	36,2	45,6
30	1	4,3	5,4	6,8	10,3	10,8	17,2	21,7	27,3	34,4	43,3
	5	4,1	5,2	6,6	10,0	10,5	16,6	20,9	26,4	33,2	41,8
	10	4,1	5,1	6,5	9,8	10,3	16,4	20,6	26,0	32,7	41,2
	25	4,0	5,0	6,4	9,6	10,1	16,1	20,2	25,5	32,1	40,4
	50	3,9	5,0	6,3	9,5	10,0	15,8	19,9	25,1	31,6	39,8
	100	3,9	4,9	6,2	9,4	9,8	15,6	19,7	24,8	31,2	39,3
40	1	3,7	4,6	5,9	8,9	9,3	14,8	18,6	23,5	29,6	37,2
	5	3,5	4,5	5,7	8,6	9,0	14,3	18,0	22,6	28,5	35,9
	10	3,5	4,4	5,6	8,4	8,8	14,1	17,7	22,3	28,1	35,4
	25	3,4	4,3	5,4	8,3	8,7	13,8	17,3	21,8	27,5	34,6
	50	3,4	4,3	5,4	8,1	8,5	13,6	17,1	21,5	27,1	34,1
	100	3,3	4,2	5,3	8,0	8,4	13,3	16,8	21,2	26,7	33,6
50	1	3,1	4,0	5,0	7,6	8,0	12,6	15,9	20,1	25,3	31,8
	5	3,0	3,8	4,8	7,3	7,7	12,2	15,3	19,3	24,3	30,6
	10	3,0	3,7	4,7	7,2	7,5	12,0	15,1	19,0	23,9	30,1
	25	2,9	3,7	4,6	7,0	7,4	11,7	14,7	18,6	23,4	29,5
	50	2,9	3,6	4,6	6,9	7,2	11,5	14,5	18,3	23,0	29,0
	100	2,8	3,5	4,5	6,8	7,1	11,3	14,3	18,0	22,6	28,5

Temperature °C	Years of service	Pipe series S									
		20	16	12,5	8,3	8	5	4	3,2	2,5	2
		Diameter/Wall thicknesses SDR									
		41	33	26	17,6	17	11	9	7,4	6	5
Allowable operation pressure bar											
60	1	2,7	3,4	4,2	6,4	6,7	10,7	13,5	17,0	21,4	27,0
	5	2,5	3,2	4,1	6,2	6,5	10,3	13,0	16,3	20,6	25,9
	10	2,5	3,2	4,0	6,1	6,4	10,1	12,7	16,0	20,2	25,5
	25	2,4	3,1	3,9	5,9	6,2	9,9	12,4	15,7	19,8	24,9
	50	2,4	3,0	3,8	5,8	6,1	9,7	12,2	15,4	19,4	24,5
70	1	2,2	2,8	3,6	5,4	5,7	9,0	11,3	14,3	18,0	22,7
	5	2,1	2,7	3,4	5,2	5,4	8,6	10,9	13,7	17,3	21,7
	10	2,1	2,6	3,3	5,1	5,3	8,5	10,7	13,5	16,9	21,3
	25	2,0	2,6	3,3	5,0	5,2	8,3	10,4	13,1	16,5	20,8
	50	2,0	2,5	3,2	4,9	5,1	8,1	10,2	12,9	16,2	20,5
80	1	1,8	2,3	3,0	4,5	4,7	7,5	9,5	11,9	15,0	18,9
	5	1,8	2,2	2,8	4,3	4,5	7,2	9,0	11,4	14,4	18,1
	10	1,7	2,2	2,8	4,2	4,4	7,0	8,9	11,2	14,1	17,7
	25	1,7	2,1	2,7	4,1	4,3	6,9	8,6	10,9	13,7	17,2
95	1	1,4	1,7	2,2	3,4	3,5	5,6	7,1	8,9	11,2	14,2
	5	1,3	1,7	2,1	3,2	3,3	5,3	6,7	8,5	10,7	13,5
	(10) ^a	(1,3)	(1,6)	(2,1)	(3,1)	(3,3)	(5,2)	(6,6)	(8,3)	(10,5)	(13,2)

^a) The values between parentheses apply in cases where it can be demonstrated that the test was carried out for more than a year at 110° C

Table 5 - Allowable operation pressures for PP-RCT, conveying water
Safety factor (SF) = 1,5

DIN 8077:2008-09

Temperature °C	Years of service	Pipe series S									
		20	16	12,5	8,3	8	5	4	3,2	2,5	2
		Diameter/Wall thicknesses SDR									
		41	33	26	17,6	17	11	9	7,4	6	5
Allowable operation pressure bar											
10	1	4,7	6,0	7,5	11,4	12,0	19,0	24,0	30,2	38,0	47,9
	5	4,6	5,8	7,3	11,1	11,6	18,4	23,2	29,3	36,9	46,4
	10	4,5	5,7	7,2	10,9	11,5	18,2	22,9	28,9	36,4	45,8
	25	4,5	5,6	7,1	10,7	11,3	17,9	22,5	28,4	35,7	45,0
	50	4,4	5,5	7,0	10,6	11,1	17,7	22,2	28,0	35,3	44,4
	100	4,3	5,5	6,9	10,5	11,0	17,4	21,9	27,6	34,8	43,8
20	1	4,1	5,2	6,6	9,9	10,4	16,6	20,9	26,3	33,1	41,7
	5	4,0	5,0	6,4	9,6	10,1	16,0	20,2	25,4	32,0	40,4
	10	3,9	5,0	6,3	9,5	10,0	15,8	19,9	25,1	31,6	39,8
	25	3,9	4,9	6,1	9,3	9,8	15,5	19,6	24,6	31,0	39,1
	50	3,8	4,8	6,1	9,2	9,6	15,3	19,3	24,3	30,6	38,5
	100	3,8	4,7	6,0	9,1	9,5	15,1	19,0	24,0	30,2	38,0
30	1	3,6	4,5	5,7	8,6	9,0	14,3	18,1	22,7	28,7	36,1
	5	3,4	4,3	5,5	8,3	8,7	13,9	17,4	22,0	27,7	34,9
	10	3,4	4,3	5,4	8,2	8,6	13,6	17,2	21,7	27,3	34,4
	25	3,3	4,2	5,3	8,0	8,4	13,4	16,9	21,2	26,8	33,7
	50	3,3	4,1	5,2	7,9	8,3	13,2	16,6	20,9	26,4	33,2
	100	3,2	4,1	5,1	7,8	8,2	13,0	16,4	20,6	26,0	32,7
40	1	3,1	3,9	4,9	7,4	7,8	12,3	15,5	19,6	24,6	31,0
	5	2,9	3,7	4,7	7,1	7,5	11,9	15,0	18,9	23,8	29,9
	10	2,9	3,7	4,6	7,0	7,4	11,7	14,7	18,6	23,4	29,5
	25	2,8	3,6	4,5	6,9	7,2	11,5	14,4	18,2	22,9	28,9
	50	2,8	3,5	4,5	6,8	7,1	11,3	14,2	17,9	22,6	28,4
	100	2,8	3,5	4,4	6,7	7,0	11,1	14,0	17,6	22,2	28,0
50	1	2,6	3,3	4,2	6,3	6,6	10,5	13,3	16,7	21,0	26,5
	5	2,5	3,2	4,0	6,1	6,4	10,1	12,8	16,1	20,3	25,5
	10	2,5	3,1	3,9	6,0	6,3	10,0	12,6	15,8	19,9	25,1
	25	2,4	3,0	3,8	5,8	6,1	9,7	12,3	15,5	19,5	24,6
	50	2,4	3,0	3,8	5,7	6,0	9,6	12,1	15,2	19,2	24,2
	100	2,3	2,9	3,7	5,7	5,9	9,4	11,9	15,0	18,9	23,8

Temperature °C	Years of service	Pipe series S									
		20	16	12,5	8,3	8	5	4	3,2	2,5	2
		Diameter/Wall thicknesses SDR									
		41	33	26	17,6	17	11	9	7,4	6	5
Allowable operation pressure bar											
60	1	2,2	2,8	3,5	5,3	5,6	8,9	11,2	14,2	17,8	22,5
	5	2,1	2,7	3,4	5,1	5,4	8,6	10,8	13,6	17,1	21,6
	10	2,1	2,6	3,3	5,0	5,3	8,4	10,6	13,4	16,8	21,2
	25	2,0	2,6	3,2	4,9	5,2	8,2	10,4	13,1	16,5	20,7
	50	2,0	2,5	3,2	4,8	5,1	8,1	10,2	12,8	16,2	20,4
70	1	1,8	2,3	3,0	4,5	4,7	7,5	9,4	11,9	15,0	18,9
	5	1,8	2,2	2,8	4,3	4,5	7,2	9,1	11,4	14,4	18,1
	10	1,7	2,2	2,8	4,2	4,4	7,0	8,9	11,2	14,1	17,8
	25	1,7	2,1	2,7	4,1	4,3	6,9	8,7	10,9	13,8	17,4
	50	1,7	2,1	2,7	4,0	4,2	6,8	8,5	10,7	13,5	17,0
80	1	1,5	1,9	2,5	3,7	3,9	6,2	7,9	9,9	12,5	15,8
	5	1,5	1,9	2,3	3,6	3,7	6,0	7,5	9,5	12,0	15,1
	10	1,4	1,8	2,3	3,5	3,7	5,9	7,4	9,3	11,7	14,8
	25	1,4	1,8	2,2	3,4	3,6	5,7	7,2	9,1	11,4	14,4
95	1	1,1	1,4	1,8	2,8	2,9	4,7	5,9	7,4	9,4	11,8
	5	1,1	1,4	1,7	2,6	2,8	4,4	5,6	7,1	8,9	11,2
	(10) ^a	(1,1)	(1,3)	(1,7)	(2,6)	(2,7)	(4,3)	(5,5)	(6,9)	(8,7)	(11,0)

^a) The values between parentheses apply in cases where it can be demonstrated that the test was carried out for more than a year at 110° C

1.14 Table of chemical resistance for PP

Environment	Conc. %	Temperature		
		20° C	60° C	100° C
Acetic acid (glacial)	97	A	B (80° C)	-
Acetic acid	50	A	A (80° C)	-
Acetic acid	40	A	-	-
Acetic acid	10	A	A	-
Acetone	100	A	A	-
Acetophenone	100	B	B	-
Acriflavine (2 % solution in H ₂ O)	2	A	A	(80° C)
Acrylic emulsions		A	A	-
Aluminum chloride		A	A	-
Aluminum fluoride		A	A	-
Aluminum sulfate		A	A	-
Alums (all types)		A	A	-
Ammonia (aqueous)	30	A	-	-
Ammonia gas (dry)		A	A	-
Ammonium carbonate	Satd.	A	A	-
Ammonium chloride	Satd.	A	A	-
Ammonium fluoride	20	A	A	-
Ammonium hydroxide	10	A	A	-
Ammonium metaphosphate	Satd.	A	A	-
Ammonium nitrate	Satd.	A	A	-
Ammonium persulfate	Satd.	A	A	-
Ammonium sulfate	Satd.	A	A	-
Ammonium sulfide	Satd.	A	A	-
Ammonium thiocyanate	Satd.	A	A	-
Amyl acetate	100	B	C	-
Amyl alcohol	100	A	B	-
Amyl chloride	100	C	C	-
Aniline	100	A	A	-
Anisole	100	B	B	-
Antimony chloride		A	A	-
Aviation fuel (115/145 octane)	100	B	C	-
Aviation turbine fuel	100	B	C	-
Barium carbonate	Satd.	A	A	-
Barium chloride	Satd.	A	A	-
Barium hydroxide		A	A	-
Barium sulfate	Satd.	A	A	-
Barium sulfide	Satd.	A	A	-
Beer		A	A	-
Benzene	100	B	C	C
Benzoic acid	A	A	-	-
Benzyl alcohol		A	A (80° C)	-
Bismuth carbonate	Satd.	A	A	-
Borax		A	A	-
Boric acid		A	A	-
Brine	Satd.	A	A	-
Bromine liquid	100	D	-	-
Bromine water	(a)	C	-	-
Butyl acetate	100	C	C	-
Butyl alcohol	100	A	A	-
Calcium carbonate	Stad.	A	A	-
Calcium chlorate	Satd.	A	A	-
Calcium chloride	50	A	A	-
Calcium hydroxide		A	A	-
Calcium hypochlorite bleach	20(a)	A	B	-
Calcium nitrate		A	A	-
Calcium phosphate	50	A	-	-

Environment	Conc. %	Temperature		
		20° C	60° C	100° C
Calcium sulfate		A	A	-
Calcium sulfite		A	A	-
Carbon dioxide (dry)		A	A	-
Carbon dioxide (wet)		A	A	-
Carbon disulfide	100	B	C	-
Carbon monoxide		A	A	-
Carbon tetrachloride	100	C	C	C
Carbonic acid		A	A	-
Castor oil		A	-	-
Cetyl alcohol	100	A	-	-
Chlorine (gas)	100	D	D	-
Chlorobenzene	100	C	C	-
Chloroform	100	C	D	D
Chlorosulfonic acid	100	D	D	D
Chrome alum		A	A	-
Chromic acid	80(a)	A	-	-
Chromic acid	50(a)	A	A	-
Chromic acid	10(a)	A	A	-
Chromic/sulfuric acid		D	D	-
Cider		A	A	-
Citric acid	10	A	A	-
Copper chloride	Satd.	A	A	-
Copper cyanide	Satd.	A	A	-
Copper fluoride	Satd.	A	A	-
Copper nitrate	Satd.	A	A	-
Copper sulfate	Satd.	A	A	-
Cottonseed oil		A	A	-
Cuprous chloride	Satd.	A	A	-
Cyclohexanol	100	A	B	-
Cyclohexanone	100	B	C	-
Decalin	100	C	C	C
Detergents	2	A	A	A
Developers (photographic)		A	A	-
Dibutyl phthalate	100	A	B	D
Dichloroethylene	100	A	-	-
Diethanolamine	100	A	A	-
Diisooctyl phthalate	100	A	A	-
Emulsifiers		A	A	-
Ethanolamine	100	A	A	-
Ethyl acetate	100	B	B	-
Ethyl alcohol	96	A	A (80° C)	-
Ethyl chloride	100	C	C	-
Ethylene dichloride	100	B	-	-
Ethylene glycol		A	A	-
Ethylene oxide	100	B (10° C)	-	-
Ethyl ether	100	B	-	-
Fatty acids (C ₆)	100	A	A	-
Ferric chloride	Satd.	A	A	-
Ferric nitrate	Satd.	A	A	-
Ferric sulfate	Satd.	A	A	-
Ferrous chloride	Satd.	A	A	-
Ferrous sulfate	Satd.	A	A	-
Fluorosilicic acid		A	A	-
Formaldehyde	40	A	A	-
Formic acid	100	A	-	-
Formic acid	10	A	A	-
Fructose		A	A	-
Fruit juices		A	A	-

Environment	Conc. %	Temperature		
		20° C	60° C	100° C
Furfural	100	C	C	-
Gas liquor		C	-	-
Gasoline	100	B	C	C
Gearbox oil	100	A	B	-
Gelatin		A	A	-
Glucose	20	A	A	-
Glycerin	100	A	A	A
Glycol		A	A	-
Hexane	100	A	B	-
Hydrobromic acid	50(a)	A	A	-
Hydrobromic acid	30(a)	A	B	D
Hydrobromic acid	20	A	A (80° C)	-
Hydrobromic acid	10	A	A (80° C)	B
Hydrobromic acid	2	A	A	A
50-50 HCl-HNO ₃	(a)	B	D (80° C)	-
Hydrofluoric acid	40	A	-	-
Hydrofluoric acid	60(a)	A	A (40° C)	-
Hydrogen chloride gas (dry)	100	A	A	-
Hydrogen peroxide	30	A	-	D
Hydrogen peroxide	10	A	B	-
Hydrogen peroxide	3	A	-	-
Hydrogen sulfide		A	A	-
Hydroquinone		A	A	-
Inks		A	A	-
Iodine tincture		A	-	-
Isooctane	100	C	C	-
Isopropyl alcohol	100	A	A	-
Ketones		A	-	-
Lactic acid	20	A	A	-
Lanolin	100	A	A	-
Lead acetate	Satd.	A	A	-
Linseed oil	100	A	A	-
Lubricating oil	100	A	B	-
Magenta dye (aqueous solution)	2	A	A some staining	-
Magnesium carbonate	Satd.	A	A	-
Magnesium chloride	Satd.	A	A	-
Magnesium hydroxide	Satd.	A	A	-
Magnesium nitrate	Satd.	A	A	-
Magnesium sulfate	Satd.	A	A	-
Magnesium sulfite	Satd.	A	A	-
Meat juices		A	A	-
Mercuric chloride	40	A	A	-
Mercuric cyanide	Satd.	A	A	-
Mercurous nitrate	Satd.	A	A	-
Mercury	100	A	A	-
Methyl alcohol	100	A	A	-
Methylene chloride	100	A	-	-
Methyl ethyl ketone	100	A	B	-
Milk and its products		A	A	A
Mineral oil	100	A	B	-
Molasses		A	A	-
Motor oil	100	A	B	-
Naphthalene	100	A	A	A
Nickel chloride	Satd.	A	A	-
Nickel nitrate	Satd.	A	A	-
Nickel sulfate	Satd.	A	A	-
Nitric acid	fuming	D	D	D

Environment	Conc. %	Temperature		
		20° C	60° C	100° C
Nitric acid	70(a)	C	D	-
Nitric acid	60	A	D (80° C)	-
Nitric acid	10	A	A	A
50-50 HNO ₃ -HCl	(a)	B	D (80° C)	-
50-50 HNO ₃ -H ₂ SO ₄	(a)	C	D (80° C)	-
Nitrobenzene	100	A	A	-
Oleic acid		A	B	-
Oleum		-	-	D
Olive oil	100	A	A	-
Oxalic acid (aqueous)	50	A	B	-
Paraffin	100	A	B	-
Paraffin wax	100	A	A	-
Petrol	100	B	C	-
Petroleum ether (boiling point 100°-140° C)	100	C	C	-
Phenol	100	A	A	-
Phosphoric acid	95	A	A	-
Plating solutions, brass		A	A	-
Plating solutions, cadmium		A	A	-
Plating solutions, chromium		A	A	-
Plating solutions, copper		A	A	-
Plating solutions, gold		A	A	-
Plating solutions, indium		A	A	-
Plating solutions, lead		A	A	-
Plating solutions, nickel		A	A	-
Plating solutions, rhodium		A	A	-
Plating solutions, silver		A	A	-
Plating solutions, tin		A	A	-
Plating solutions, zinc		A	A	-
Potassium bicarbonate	Satd.	A	A	-
Potassium borate	1	A	A	-
Potassium bromate	10	A	A	-
Potassium bromide	Satd.	A	A	-
Potassium carbonate	Satd.	A	A	-
Potassium chlorate	Satd.	A	A	-
Potassium chloride	Satd.	A	A	-
Potassium chromate	40	A	A	-
Potassium cyanide	Satd.	A	A	-
Potassium dichromate	40	A	A	-
Potassium ferri-/ferrocyanide		A	A	-
Potassium fluoride		A	A	-
Potassium hydroxide	50	A	A	-
Potassium hydroxide	10	A	A	A
Potassium nitrate	Satd.	A	A	-
Potassium perborate	Satd.	A	A	-
Potassium perchlorate	10	A	A	-
Potassium permanganate	20	A	A	-
Potassium sulfate		A	A	-
Potassium sulfide		A	A	-
Potassium sulfite		A	A	-
Propyl alcohol	100	A	A	-
Pyridine	100	A	-	-
Silicone oil	100	A	A	-
Soap solution (concentrated)		A	A	-
Sodium acetate		A	A	-
Sodium bicarbonate	Satd.	A	A	-
Sodium bisulfate	Satd.	A	A	-
Sodium bisulfite	Satd.	A	A	-

Environment	Conc. %	Temperature		
		20° C	60° C	100° C
Sodium borate		A	A	-
Sodium bromide oil solution		A	A	-
Sodium carbonate	Satd.	A	A	-
Sodium chlorate	Satd.	A	A	-
Sodium chloride	Satd.	A	A	A
Sodium chlorite	2	A	A (80° C)	-
Sodium chlorite	5	A (80° C)	A	-
Sodium chlorite	10	A (80° C)	A	-
Sodium chlorite	20	A (80° C)	A	-
Sodium cyanide	Satd.	A	A	-
Sodium dichromate	Satd.	A	A	-
Sodium ferricyanide	Satd.	A	A	-
Sodium ferrocyanide	Satd.	A	A	-
Sodium fluoride	Satd.	A	A	-
Sodium hydroxide	50	A	A	-
Sodium hydroxide	10	A	A	A
Sodium hypochlorite	20	A	B	B
Sodium nitrate		A	A	-
Sodium nitrite		A	A	-
Sodium silicate		A	A	-
Sodium sulfate	Satd.	A	A	-
Sodium sulfide	25	A	A	-
Sodium sulfite	Satd.	A	A	-
Stannic chloride	Satd.	A	A	-
Stannous chloride	Satd.	A	A	-
Starch		A	A	-
Sugars and syrups		A	A	-
Sulfamic acid		A	A (80° C)	-
Sulfates of Calcium and magnesium	Satd.	A	A	-
Sulfates of potassium and sodium	Satd.	A	A	-
Sulfur		A	A	-
Sulfuric acid	98(a)	C	-	D
Sulfuric acid	60	A	B (80° C)	-
Sulfuric acid	50	A	B	-
Sulfuric acid	10	A	A	A
50-50 H ₂ SO ₄ /HNO ₃	(a)	C	D (80° C)	-
Tallow		A	A	-
Tannic acid	10	A	A	-
Tartaric acid		A	A	-
Tetrahydrofuran	100	C	C	C
Tetralin	100	C	C	C
Toluene	100	C	C	-
Transformer oil	100	A	C	-
Trichloroacetic acid	10	A	A	-
Trichloroethylene	100	A	A (80° C)	-
Turpentine	100	C	C	C
Urea		A	A	-
Urine		A	A	-
Water (distilled, soft, hard and vapor)		A	A	A
Wet chlorine gas		-	D (70° C)	-
Whiskey		A	A	A
White Paraffin	100	A	B (80° C)	-
White spirit	100	B	C	-
Wines		A	A	-
Xylene	100	C	C	C

Environment	Conc. %	Temperature		
		20° C	60° C	100° C
Yeast		A	A	-
Zinc chloride	Satd.	A	A	-
Zinc oxide		A	A	-
Zinc sulfate	Satd.	A	A	-

(a) May produce cracking in material under stress

This chart shows the chemical resistance of polypropylene resin under static conditions and not under pressure.

Note: the user is advised to carry out his/her own tests to determine the suitability of polypropylene in a particular environment.

A = Negligible effect

The material should be suitable for all applications where these environmental conditions exist.

B = Limited absorption or attack

The material should be suitable for most applications but the user is advised to carry out his/her own tests to determine the suitability of polypropylene in a particular environment.

C = Extensive absorption and/or rapid permeation

The material should be suitable for applications where only intermittent service is involved, or where the swelling produced has no detrimental effect on the part. The user should carry out his/her own tests to determine the suitability of polypropylene in a particular environment.

D = Extensive attack

The specimen dissolves or disintegrates. Polypropylene is not recommended.

Note:

This table should be used only as a guide. Polypropylene subjected to mechanical stress may behave different and show different result. For any doubts we recommend to contact the K-Aqua Customer Service.

1.15 Material Properties Transition/Threaded Parts

Transition/threaded parts:



Male thread



R = Conical male thread acc. to ISO 7 / DIN EN 10226

Female thread

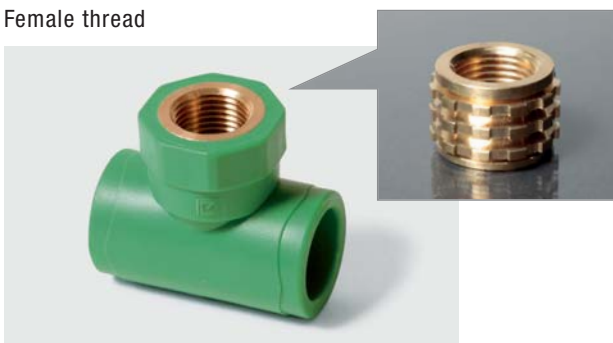

Rp = Cylindrical female thread acc. to ISO 7 / DIN EN 10226



Rc = Conical female thread acc. to ISO 7 / DIN EN 10226

Note: Threaded parts acc. to ISO 7 / DIN EN 10226 additional seal recommended (e.g. PTFE tape for sealing)

Threaded parts acc. to EN – ISO 228 additional seal required (gasket or O-ring)

The K-Aqua threaded parts have a special designed profile that avoids the turning of the insert once it is injected!





2

Quality Assurance

Page

2.1 Quality assurance systems	34
2.2 Pressure tests	34
2.3 System control	35
2.4 Internal control	35
2.5 Testing and accepting incoming goods	35
2.6 In-process inspection	35
2.7 Process control	36
2.8 Final inspection	36
2.9 External control	36
2.10 Guarantee	36
2.11 Certificates	37

2.1 Quality Assurance Systems

Various national and international authorities and institutions provide regulatory supervision on quality control measurements. The external supervision for pipes & fittings for potable cold & hot water system certificates from abroad are given by SKZ or IMA, who is

authorized by the DVGW (German institute for gas and water) as controlling organization. External supervision aims to audit **quality assurance systems** by which test equipments and procedures verify installation standards, as well as hygienic and toxicity tests.

2.2 Standards

ISO 15874	Plastic piping system for hot and cold water installations – Polypropylene (PP)
Part 1	General
Part 2	Pipes
Part 3	Fittings
Part 5	Fitness for purpose of the system
Part 7	Recommendations for the assessment of conformity
DIN 8077	Polypropylene (PP) pipes – PP-H, PP-B, PP-R, PP-RCT – dimensions
DIN 8078	Polypropylene (PP) pipes – PP-H, PP-B, PP-R, PP-RCT – general quality requirements and testing
DIN 16962	Pipe joints and components for pressure systems of Polypropylene (PP)
DIN 16928	Pipes of Thermoplastic Materials, Pipe Joints, Elements for Pipes, Laying; General Directions
DVGW	
W544	Plastic pipe systems for drinking water – pipes
W534	Plastic pipe systems for drinking water – fittings
W270	Assesment of microbiological growth
DVS 2207-11	Socket welding, butt-welding and electrofusion welding of Polypropylene pipes and components
DVS 2208-1	Machines and tools for the welding of Polypropylene pipes and components
ISO 7 / EN 10226	Pipe threads where pressure tight joints are done on the thread
EN - ISO 228	Pipe threads where pressure tight joints are not made on the threads

2.3 System Control

The production of **K-Aqua** superior German quality piping system calls for the regulation and control of all areas of the operations. All results are documented and archived:

- Testing and accepting incoming goods
- Process control
- In-process inspection
- Final inspection tests

Regulations for the quality control of **K-Aqua** sanitary piping system include:

- DIN-guidelines
- DVGW working sheets
- Supervisory Regulations of IMA Dresden

These standards and guidelines feature the minimum requirements for internal control.

Conformance to the superior quality standards is verified through independent authorities, by internal audits and laboratory tests. **K-Aqua** highest quality standard is controlled by IMA Dresden.

Kessel Wassertechnologie GmbH is a highly qualified and experienced manufacturer in extrusion and injection moulding. This is reflected in our internal quality standards and procedures, which are illustrated by the constant quality of our products.

2.4 Internal Control

A team of highly trained and qualified QC engineers, equipped with a state of art laboratory, ensures that all tests are carried out in compliance with our quality control policies, which includes:

- Testing all raw material
- Measuring and inspecting our production equipments
- Auditing our production procedures
- A final inspection for the quality of our finished products
- All internal quality audits are documented and archived in accordance with the highest standard quality control policies

2.5 Testing and Accepting Incoming Goods

All incoming goods are carefully inspected, to ensure that the raw material conforms with the set requirements. Goods that have not been tested do not get released for production.

The incoming raw material is tested according to DIN EN ISO 1133.

2.6 In-Process Inspection

The quality plan requires that all inspections are carried out at the beginning as well as during production. As production starts all relevant data are checked by the Quality Assurance Department. Pre-production samples are tested by the laboratory technicians for:

- Surface finish
- Dimensional accuracy
- Data from extrusion and injection moulding machines
- The product is only released if optimal test results are achieved

2.7 Process Control

We have an extensive quality control process in the field of extrusion and injection. This enables constant observation and control of production. This ensures that only perfect quality products are packed and stored. All data received during production is studied and analyzed, in details.

2.8 Final inspection

QC requires that inspections and tests are carried out on all finished products. The results are all documented. Finished products are only released to storage when all tests and inspections have conformed to the authorized procedures and specifications. The final inspection test includes a time laps procedure. This measures the usability of the products in their field of application, as well as removing production weaknesses. These inspections are the method for quality assurance during production and for design tests. The results document the system quality and serve to optimize the manufacturing process.

The final inspection covers the following procedures:

- Dimensional control
- Surface finish
- Measurement of the melt flow index
- Impact bending test
- Heat reversion test
- Homogeneity of the material
- Behavior under long period of stress

2.9 External Control

External supervision consists of measuring the fixed scope at fixed intervals. The respective supervising institutions appoint the appropriate authorized inspection organization to carry out external supervision. Inspection includes:

- External tests of products
- Internal audit of **K-Aqua** quality assurance system and test procedures
- Calibration of the test equipment
- Hygienic and toxicity tests

2.10 Guarantee

When **K-Aqua** components are correctly installed and used, the trouble free and satisfactory operation of the installed system can be expected on the long run. Should a fault ever occur, however, our after sales service is ready to help you.

Purchases of **K-Aqua** components are covered by the guarantee rights stipulated in the purchase contract with your dealer. In accordance with the provisions of law (product liability) the manufacturer is responsible within the scope of the German product liability legislation for damage and injury caused to objects and persons respectively by faulty **K-Aqua** components. A guarantee of 10 years is granted on all the pipes and fittings manufactured and distributed by **K-Aqua**, within the scope of the German product liability legislation and the manufacturer's liability insurance.

Product liability insurance

For the coverage of our liability for product damage (personal injury and material damage and especially dismantling and installation costs), we have concluded an extended business and product liability insurance.

2.11 Certificates/External supervision



2
Quality Assurance

kiwa

TÜVRheinland®
DIN CERTCO

Product liability insurance:

For the coverage of our liability for product damage (personal injury and material damage and especially dismantling and installation costs), we have conducted an external business and product liability insurance which is valid for 10 years.

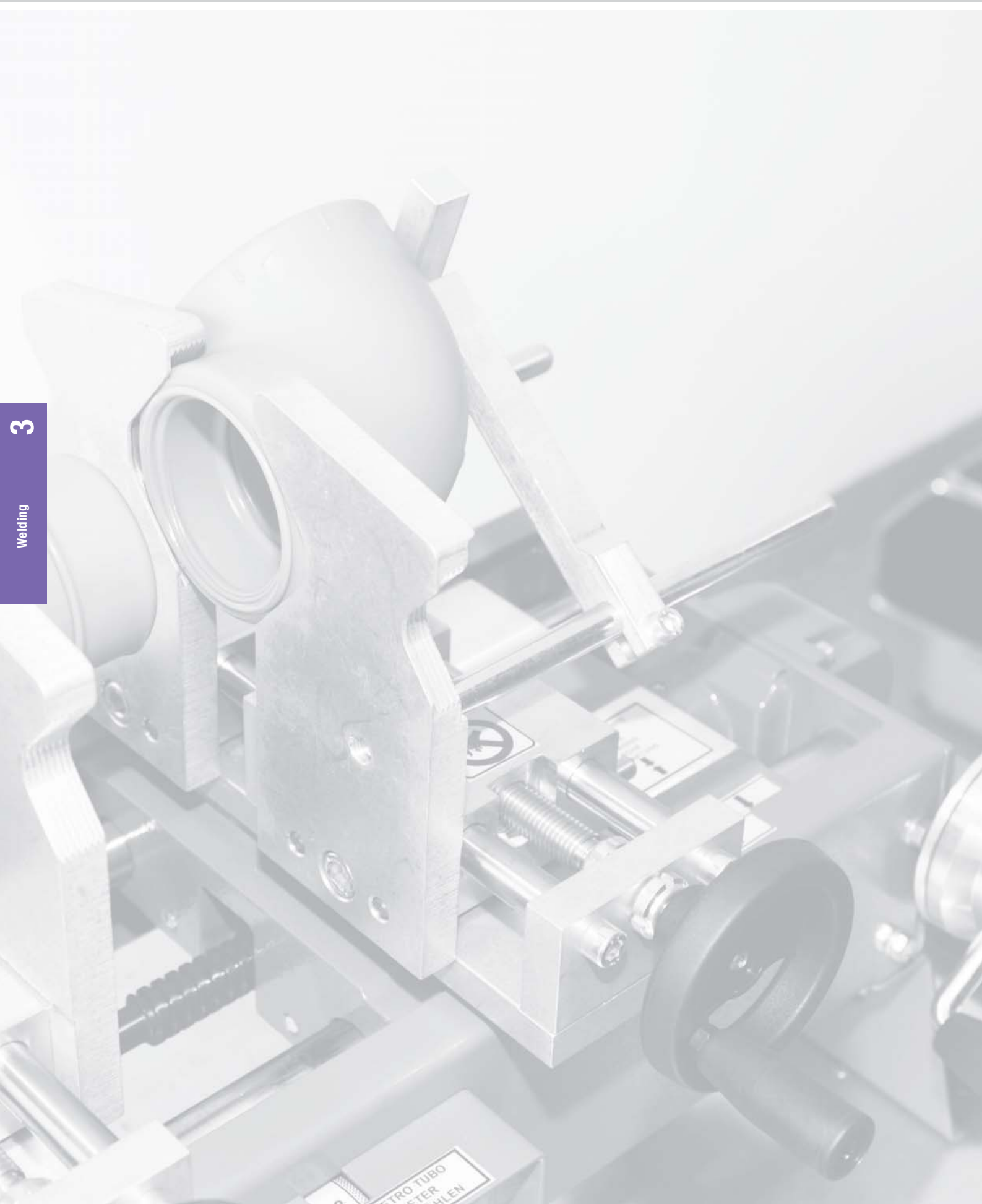



3	Welding	Page
	3.1 Welding tools	40
	3.2 Hand welding machine	40
	3.3 Welding machine	40
	3.4 Welding procedure	40 - 41
	3.5 Socket welding machine - working steps	42
	3.6 Hole repair	43
	3.7 Electrofusion welding machine - working steps	44
	3.8 Butt welding	45 - 46

3.1 Welding Tools

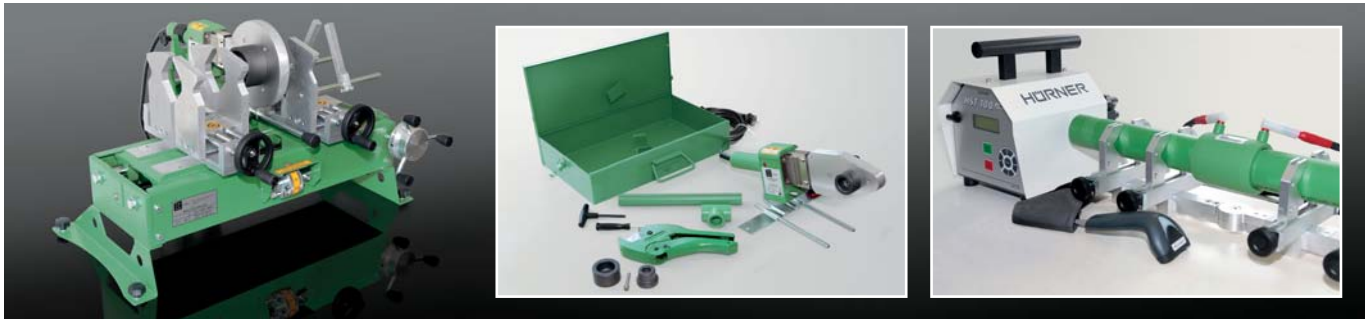

3.2 Hand Welding Machine Type AQ98063/AQ98032

Our polyfusion devices are delivered as a kit in a metal box. The thermoelement has an electrical thermostat which controls the temperature automatically. The polyfusion device runs at 230 V. Depending of the type that you need we provide the kits in two versions:
 Type AQ98032 consists of Polywelder and bushes dim 20-32
 Type AQ98063 consists of Polywelder and bushes dim 20-63

3.3 Welding Machine Type AQ988125

These are welding devices for on-site use, suitable for polyfusion socket welding pipes and fittings according to the regulations currently in force. These devices consist of:

- A self-centering clamp system, which achieves perfect welding
- A manual selector switch to ensure correct welding
- A thermo-element which controls temperature electronically
- A series of coated bushes with non-stick material
- A tripod to support the pipe
- A transport case

Note: This device requires a 220 V power supply and features 700 W power. The presses and their accessories are supplied in a metal box.

3.4 Welding Procedure

The **K-Aqua** pipework is coupled by socket fusion. The welded pipes and fittings have a longitudinally overlapping connection. The heating of the pipes' ends and fitting faucets is done by a heating element with bushes. After the necessary welding temperature is reached, the joining process is done. The pipe and fitting faucets diameters, as well as the respective heating bush diameters, are matched to build up the necessary pressure during the jointing process. The heating element is electrically heated it complies with DVS Directive 2208 part 1 in construction and accuracy.

3.4.1 Preparations

Cut the pipe using a pipe cutter that is suitable for plastic pipes (Fig. 1). The pipe end and fitting faucet, to be thoroughly cleaned with absorbent paper. Second, marking the bush depth on the pipe (Fig. 2) while bringing the heating element to 260° C (remember that the temperature tolerance is $\pm 10^\circ \text{C}$) by checking the integrated thermometer on the heating element. Otherwise the temperature must be controlled and measured by an appropriate measuring device.

Note: Must not start heating the joint parts before reaching the set temperature of 260° C. Also cleaning the mandrel and bush before each use.

3.4.2 Welding

Starting with pushing the pipe and fitting ends, quickly and axially, up to the stop of the mandrel and the marked insertion depth (Fig. 3), respectively fast without torsion. The heating of the joint faces is done according to the table A. When the heating period is up, the pipe and fitting ends are pulled abruptly from the heating element (Fig. 4) and joined immediately without torsion, minding the correct insertion depth (Fig. 5 and 6).

Note: We recommend fixing the tow joint part again for a certain time (the heating period). Do not expose the welded joint to mechanical stress until after the cooling period is done.

Pipe \varnothing	Heating-up time (sec)	Processing time (sec)	Cooling-down time (min.)	Welding depth (mm)
20	5	4	2	14
25	7	4	2	15
32	8	6	4	17
40	12	6	4	18
50	18	6	4	20
63	24	8	6	26
75	30	8	6	29
90	40	8	6	32
110	50	10	8	35
125	60	10	8	41

Table A

Hand welding - working steps welding together

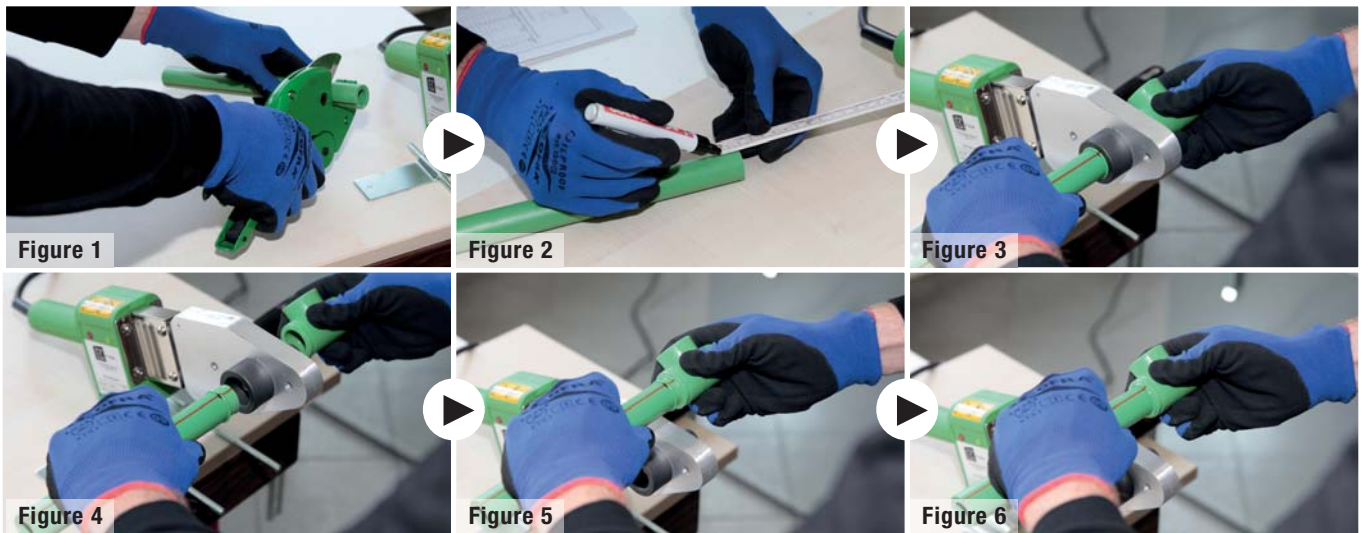

Note: If welding is to be carried out outdoors when the temperature is below +5° C, the heating up time in acc. with DVS 2207 Part 11 should be increased by 50 %.

3.5 Socket Welding Machine Article AQ988125 - working steps welding together

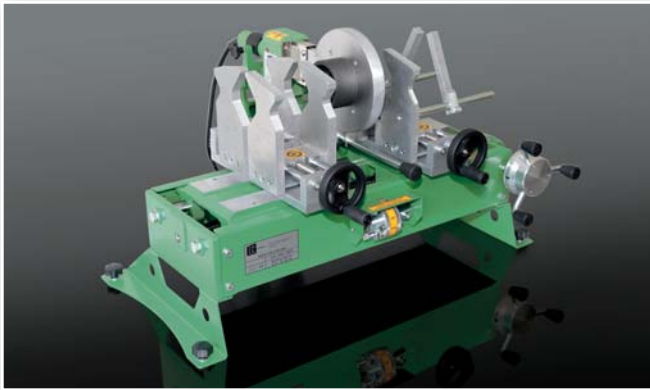

Socket welding machine equipped with movement slides on which prismatic clamps are placed to allow an automatic self-centering of any kinds of pipes and fittings. The socket welding machine is delivered in a metal transport box.

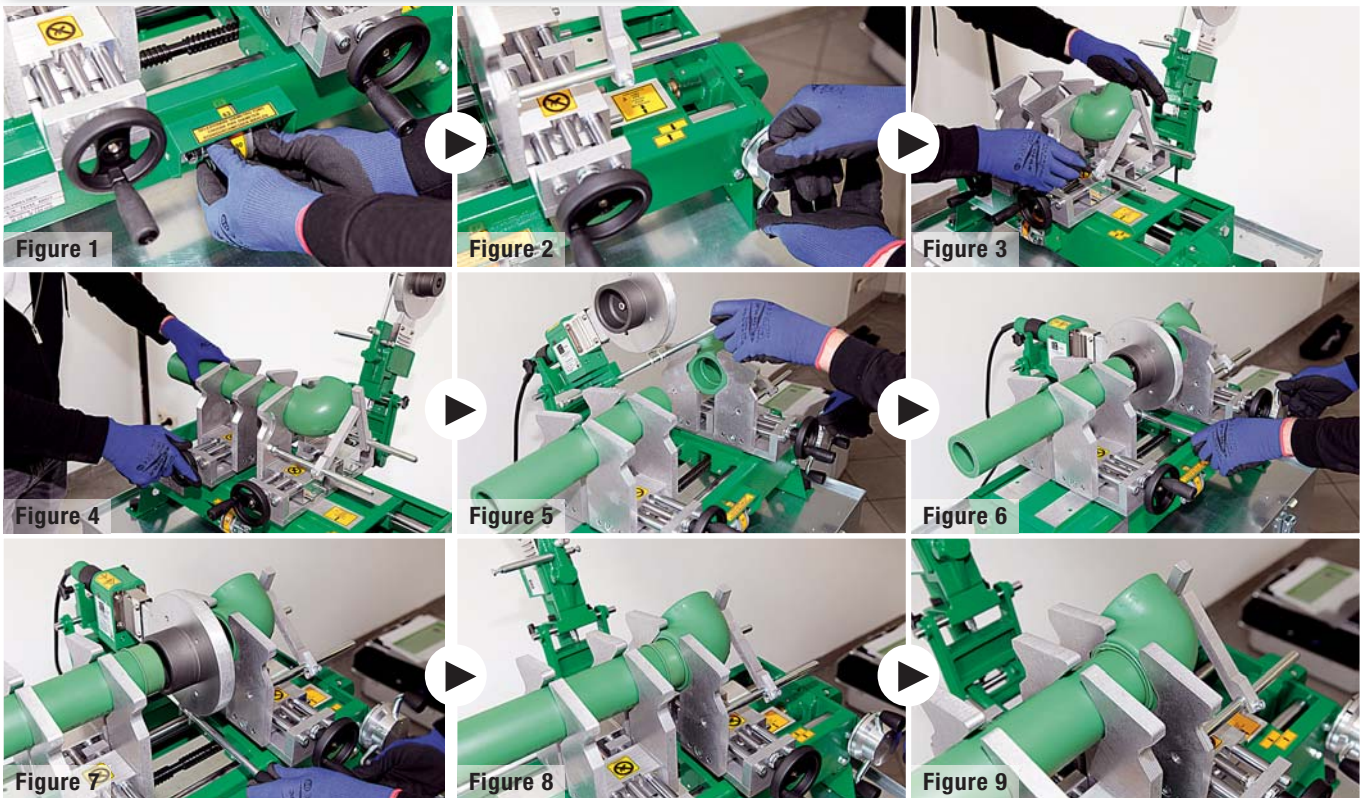

Select the pipe/fittings diameter (Fig. 1) and adjust the position of the slides (Fig. 2). Press the fitting into the clamping tool up to the stop and fix it (Fig. 3). Adjust the stop to hold the fitting. Align the pipe axially into the fitting (Fig. 4). Check the welding plate temperature and adjust it if necessary. Move the welding plate between pipe and fitting (Fig. 5). Slide the pipe and fitting at the same time into the heating tools (Fig. 6) up to the stop.

Hold this position for the heating-up time acc. to Table A (see page 41). After the heating-up time is reached move the slide back, move out the welding plate and join the pipe and fitting rapidly together (Fig. 7, 8, 9) moving the slide up to the stop. Remove the welding joint after the end of the cooling time from the clamping jaws.

3.6 Hole Repair in case of Damaged Pipe

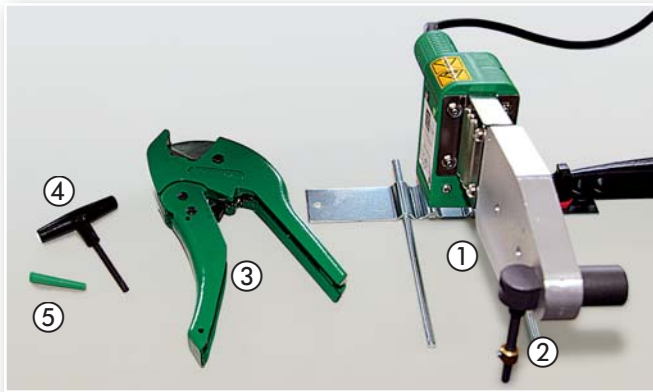

In case a **K-Aqua** pipe is damaged, it is possible to be repaired, using a special tool, mounted on the polyfusion device with a special repair patch (type AQ5937/AQ59311).

Note: The repaired part can work again under pressure.

Tool set hole repair:

- ① Hand welding machine
- ② Welding tool for repairing plug
- ③ Pipe cutter
- ④ Imbus key
- ⑤ Repairing plug



Figure 1



Figure 2



Figure 3



Figure 4



Mark the degree of the push-in depth (wall thickness) on the repair plug (Fig. 1). Distance tool to be fixed according to the wall thickness of the pipe and tighten the screw. Heat up the borehole and the welding plugs with the repair set for 15 seconds (Fig. 2).

After removing the welding device, set in the repair plug precisely without twisting it (Fig. 3). After a cooling time of 5 minutes, remove the protruding end of the repair plug (Fig. 4).

3.7 Electrofusion Welding with Electrofusion Machine Type AQ990

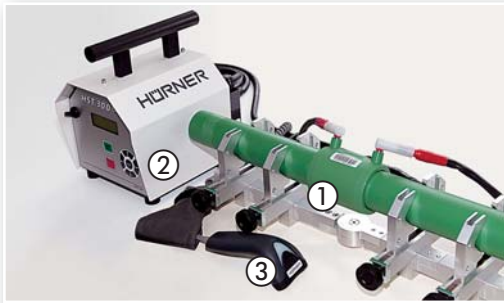

- ① Electrofusion socket
- ② Electrofusion machine
- ③ Scanner

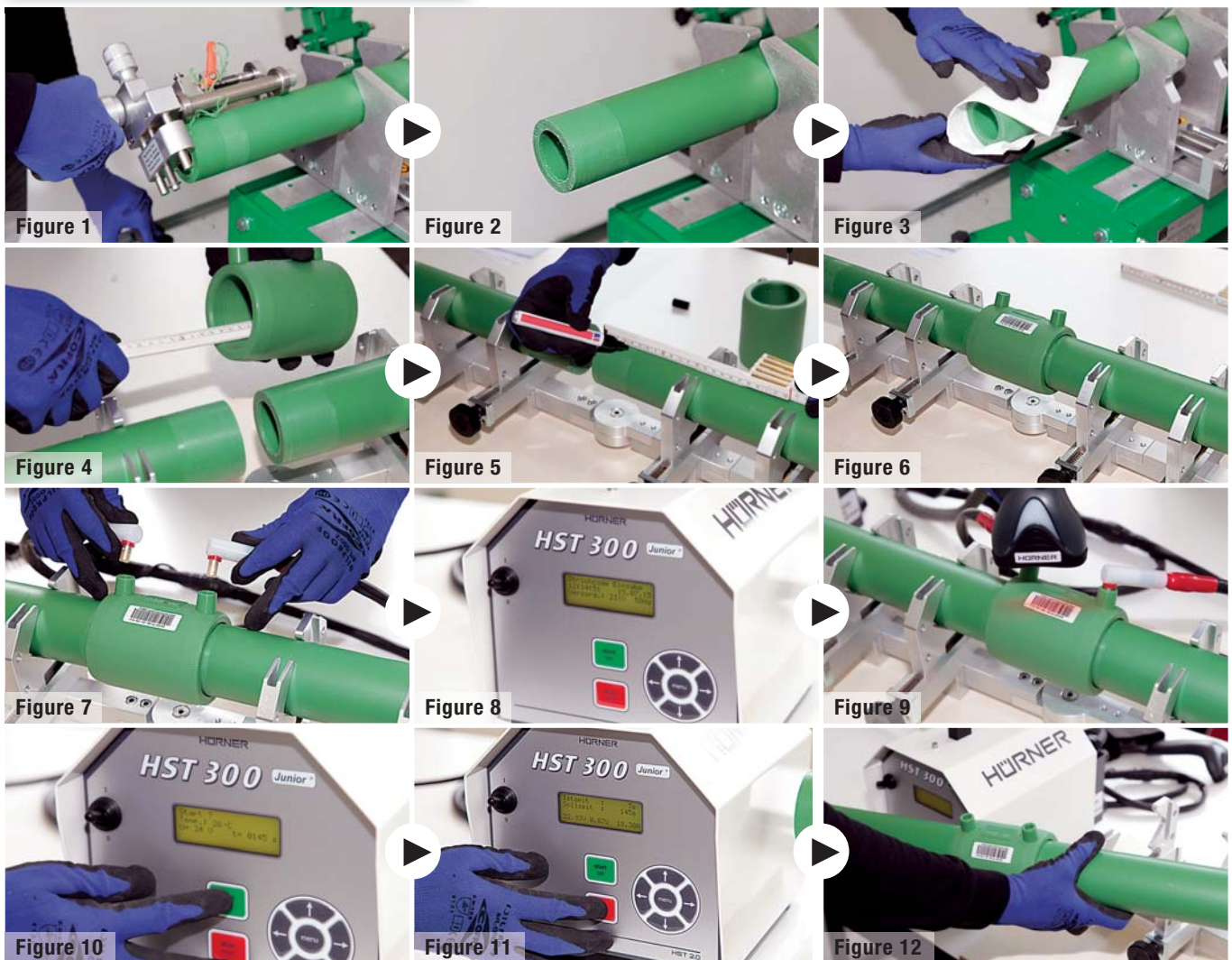

Cut the pipe properly in rectangularly position. Afterwards remove the oxidation layer in the welding area. Use a hand scraper (code AQ974) or a rotary scraper (Fig. 1). Once the surface is scraped properly (Fig. 2) clean the pipe surface and the inside coupler with absorbent, lint-free and non-dyed paper (Fig. 3). Mark the depth of the coupler (Fig. 4 and 5). Slide in the coupler up to the marked position on the pipe. It's recommended to secure the pipe against dislocation, e.g. with a pipe clamp (Fig. 6). Connect the cables to the contact pins of

the coupler (Fig. 7) and start welding process (Fig. 8). You can neither insert the datas manually acc. to the datas mentioned on the barcode label of the socket or you can use the barcode reader (Fig. 9). Afterwards proceed with the welding following the steps mentioned on the welding machine (Fig. 10 and 11). At the end of the welding cycle (Fig. 12) wait for the cooling time. After the cooling time you can stress the electrofusion joint to the permissible operation pressure.

3.8 Butt Welding

The welding machine part no. AQ989250 is suitable for butt welding of pipes and/or fittings made of PP-R / PP-RCT from dia = 90 mm up to dia = 250 mm

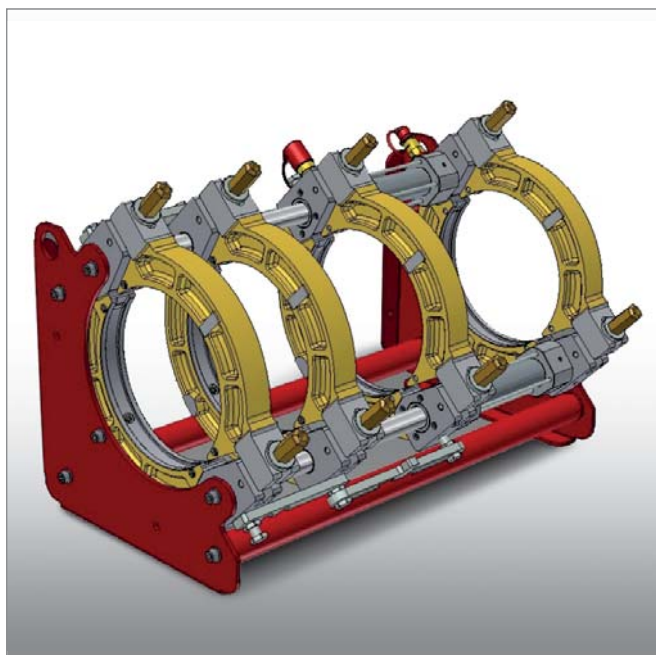

The butt welding machine with heating element part no. AQ989250 includes:

- Basic machine with movable slide
- Heating element
- Hydraulic aggregate
- Electrical planing tool
- Flexible hydraulic hoses
- Metal box for electrical heating elements and planing tool.

Preparation

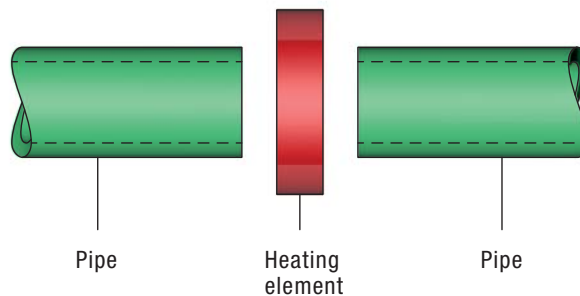

Heating up

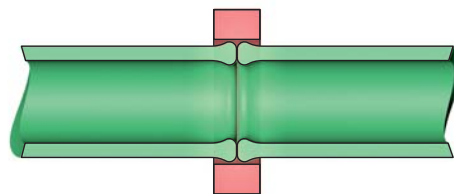

Finished connection

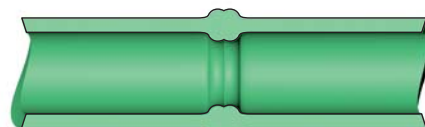

Process steps in heated tool butt welding

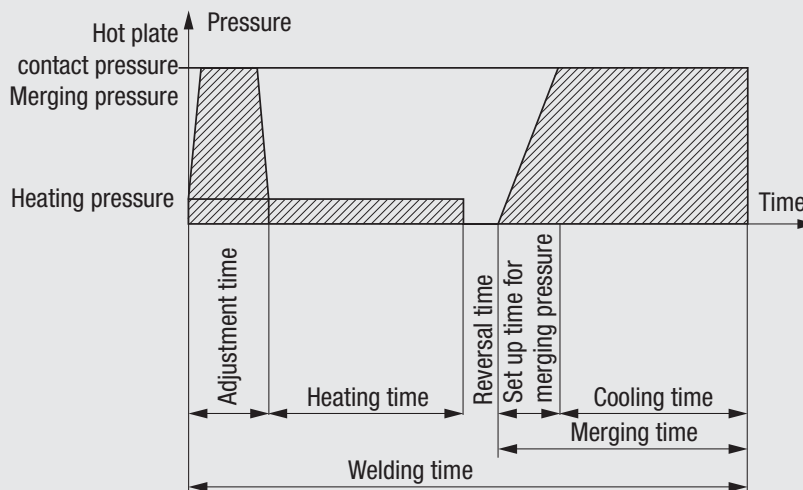

Butt Fusion welding procedure

1. Create permissible working conditions.
2. Align and clamp the parts to be welded, e. g. with dollies.
3. Clean the joining faces beyond the welding area with a cleaning agent 3.2.3 with unused, absorbent, non-fraying and non-dyed paper. Machine the joining faces, in the case of pipes using a plane (for example).
4. Take out the plane in the case of a pipe welding machine.
5. Remove the chips from the welding area without touching the joining faces.
6. Check the plane parallelism by moving the joining faces together (max. gap width according to Table 1).
7. Check the misalignment (max. 0.1 x wall thickness).
8. Check the heated tool temperature ($210 \pm 10^\circ \text{C}$).
9. Clean the heated tool with a cleaning agent with unused, absorbent, non-fraying and non-dyed paper and ensure extraction.
10. Determine the movement pressure or the movement force before every welding operation and make a note of it on the welding record sheet.
11. Determine the setting values for the alignment, heating-up and joining pressures.
12. Stipulate the guide values according to Table 2.
13. Move the heated tool into the welding position.
14. Align the faces to the heated tool until a bead arises (according to Table 2).
15. Heating-up at a reduced pressure $\leq 0.01 \text{ N/mm}^2$, heating-up time according to Table 2
16. At the end of the heating-up, detach the joining faces to be welded from the heated tool and move this out of the welding position.
17. Within the changeover time, quickly move together the faces to be welded until they almost touch. The faces must come into contact at a speed of nearly zero. Immediately afterwards, build up the joining pressure with a linear rise in the build-up time (Table 2).
18. A bead must exist after the joining at a pressure of 0.10 N/mm^2 . According to Figure 1, K must be > 0 at every point.
19. Cooling under the joining pressure according to Table 2,
20. Unclamping of the welded parts when the cooling time has elapsed.
21. Complete the welding record sheet (can be provided upon request).

Table 1:
Maximum Gap Widths between the Machined Welding Faces

Pipe outside diameter d mm	Gap width mm	Panel width mm
≤ 355	0.5	
400... < 630	1.0	$\leq 1,500$
630... < 800	1.3	$> 1,500 \leq 2,000$
800... $\leq 1,000$	1.5	$> 2,000 \leq 2,300$
$> 1,000$	2.0	$> 2,300 \leq 3,000$

Table 2: Parameters for Welding Machines Type OMISA SP

dia	SDR	Merging pressure bar	Bead height mm	Heating time sec.	Welding pressure bar	Cooling time min.
160	17	8	1	147	8	16
	11	13	1	225	13	24
200	17	13	1	180	13	20
	11	20	1	290	20	30
250	17	21	1	217	21	24
	11	32	1,5	313	32	35

Permissible misalignment of wall 0,1 x wall thickness (s)

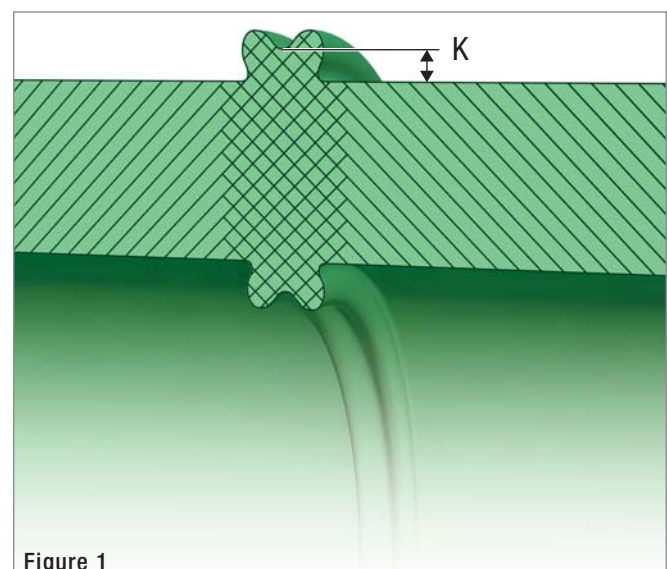

Figure 1



4

Installation

Page

4.1 Installation	48
4.2 Thermal instalation of cold water pipes	48
4.3 Applications in sanitary installation shaft	48
4.4 Design and realization	48
4.5 Operation conditions	49
4.6 Pressure loss in K-Aqua pipes	50 - 52
4.7 Pressure loss in K-Aqua fittings	52
4.8 Linear deformation under heat influence	52
4.9 Distance between the supporting points	55 - 58
4.10 Length variation of K-Aqua pipes due to heat	59
4.13 System testing	59

4.1 Installation

K-Aqua unrivalled as it is a unique poly-fusion connection system. It can be installed in no time; for instance, a 20 mm external diameter pipe takes only 9 seconds to install.

4.2 Thermal Installation of Cold Water Pipes

As stipulated in section 2 of the DIN 1988 Standard, drinkable water facilities must be protected from heat and condensation. The diagram below reports the standard values for minimum insulation thickness. Those figures can be applied to all types of pipes, including **K-Aqua**. (Fig. 1)

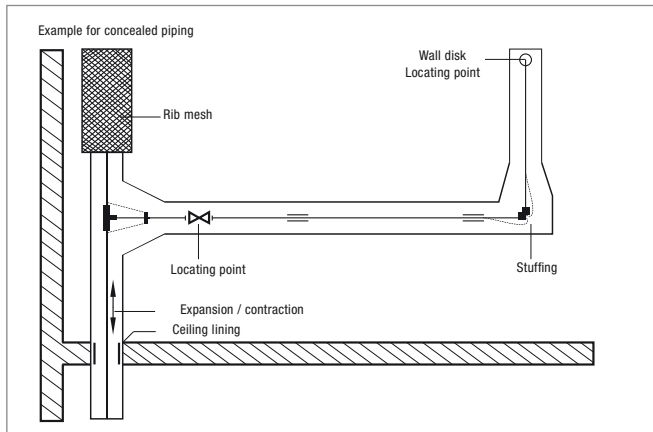
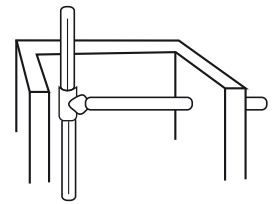

Figure 1

4.3 Applications in Sanitary Installation Shaft

When installing an apartment's pipe connections from the main pipe, the following techniques can be applied to compensate for the pipe's thermal expansions: (Fig. 2)

Pipe connection can be made at some distance, away from the wall.



Connecting pipe can be passed through a hole much larger than the pipe diameter.

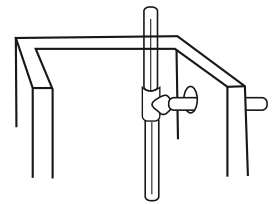

Appartment connection can be made through a branch pipe to provide flexibility.

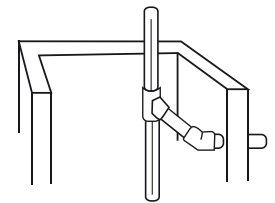

Figure 2

4.4 Design and Realization

Realization and installation must be performed according to the specific standards of the countries of application.

4.5 Operation Conditions

Classification of operating conditions to DIN EN ISO 15874-1

The selection of a particular application class according to the following table should be agreed among the contracting parties.

For each application class an allowable operating pressure p_0 of 4 bar¹⁾, 6 bar, 8 bar or 10 bar applies, depending on the application.

Applicatio class	Calculation-temperature TD °C	Service life ^{b)} at T _D Years	T _{max} °C	Service life at T _{max} Year(s)	T _{mal} °C	Service life at T _{mal} h	Typical application area	PP-R pipe system SDR 6	PP-RCT pipe system SDR 7,4
1 ^{a)}	60	49	80	1	95	100	Hot water supply (60° C)	10 bar	10 bar
2 ^{a)}	70	49	80	1	95	100	Hot water supply (70° C)	8 bar	10 bar
4 ^{b)}	20 Followed by 40 Followed by 60 Followed by (see next column)	2,5 20 25 (see next column)	70 Followed by (see next column)	2,5 (see next column)	100	100	Floor heating and low temperature radiator connections	10 bar	10 bar
5 ^{b)}	20 Followed by 60 Followed by 80 Followed by (see next column)	14 25 10 (see next column)	90 Followed by (see next column)	1 (see next column)	100	100	High temperature radiator connections	6 bar	8 bar

- a) Pertinent to the national regulations either application class 1 or application class 2 may be selected.
- b) If there is more than one operational temperature for one application area the corresponding service life time should be summed. For example the temperature collective for class 5 for a period of 50 years consists of:
- 20° C over 14 years followed by
 - 60° C over 25 years followed by
 - 80° C over 10 years followed by
 - 90° C over 1 year followed by
 - 100° C over 100 h

Explanation:

The column **T_{mal}** indicates the highest allowed temperature (for example at disruption of the controlling), max 100° C. The column **Service life at T_{mal}** shows that this breakdown temperature allows a max period of 100 h (over 50 years) whereas single breakdown segments should not exceed 3 hours.

REMARK:

This norm does not apply when higher values are assigned to T_D, T_{max} and T_{mal} than those quoted on the table.

Figure 3

¹⁾ 1 bar = 10⁵ N/m² = 0,01 MPa

4.6 Pressure loss pipes

Pressure loss PP-R/PP-RCT pipes SDR 6 with water temperature at 10° C

Flow rate	∅	∅	∅	∅	∅	∅	∅	
l/s	kg/h	16x2,7	20x3,4	25x4,2	32x5,4	40x6,7	50x8,4	63x10,5
	70	10 0,22	2 0,14	0,9 0,09	Head loss in mm c.a./m Average speed in m/s			
	140	33 0,44	8 0,29	3 0,18	1 0,11			
0,05	180	52 0,57	13 0,37	4 0,23	2 0,14			
	220	73 0,70	19 0,45	6 0,28	2 0,17			
	290	118 0,92	30 0,59	10 0,37	4 0,23	1,5 0,15	0,5 0,09	
0,1	360	164 1,11	42 0,71	15 0,45	6 0,28	2 0,18	0,7 0,11	
	430	234 1,36	61 0,88	21 0,55	8 0,34	3 0,22	1,07 0,14	0,33 0,09
	510		83 1,04	29 0,66	11 0,40	4 0,26	1,44 0,16	0,45 0,10
	580		104 1,18	37 0,75	14 0,46	5 0,29	1,8 0,19	0,56 0,12
	655		129 1,34	45 0,84	18 0,52	6 0,33	2,2 0,21	0,7 0,13
0,2	730		156 1,49	55 0,94	22 0,58	7,5 0,37	2,69 0,24	0,84 0,15
	830		290 1,65	69 1,07	27 0,66	9 0,42	3,3 0,27	1 0,17
	900		353 1,83	85 1,20	33 0,74	11 0,47	4,1 0,30	1,3 0,19
0,3	1080			110 1,39	43 0,85	15 0,54	5,3 0,35	1,6 0,22
	1280			149 1,65	59 1,01	20 0,64	7,1 0,41	2,2 0,26
0,4	1430			270 1,85	71 1,13	24 0,72	8 0,46	2,7 0,29
	1605				87 1,27	30 0,81	10 0,52	3,4 0,32
0,5	1805				107 1,43	36 0,91	13 0,58	4,2 0,36
	2005				135 1,55	44 1,01	15 0,65	5 0,40
0,6	2155				172 1,70	50 1,08	17 0,69	5,7 0,43
	2330				200 1,8	57 1,17	20 0,75	6,5 0,47
0,7	2530				225 1,98	66 1,27	23 0,82	7,6 0,51
	2705					74 1,36	26 0,87	8,5 0,54
0,8	2880					83 1,45	29 0,93	9,5 0,58
	3005					89 1,51	31 0,97	10 0,61
0,9	3255					103 1,63	36 1,05	11 0,66

Flow rate	∅	∅	∅	∅	∅	∅	∅	∅	
l/s	kg/h	32x5,4	40x6,7	50x8,4	63x10,5	75x10,5	90x12,5	110x15,2	125x20,8
1,0	3600		143 1,8	43 1,16	14 0,73	7,9 0,5	2,8 0,35		
1,2	4320		198 2,16	59 1,40	19 0,87	9,2 0,61	3,9 0,42		
1,3	4680			66 1,49	22 0,93	10,6 0,66	4,5 0,46		
1,4	5040			76 1,62	25 1,01	12,1 0,71	5,1 0,50		
1,6	5760			114 1,85	32 1,16	15,3 0,81	6,4 0,57		
1,8	6480			141 2,08	40 1,32	18,8 0,92	7,9 0,64		
2,0	7200			170 2,31	48 1,46	22,7 1,02	9,5 0,71	3,7 0,48	
2,2	7920				57 1,60	26,9 1,12	11,3 0,78	4,4 0,52	
2,4	8640				66 1,74	31,4 1,22	13,1 0,85	5,1 0,57	
2,6	9360				76 1,88	36,1 1,32	15,1 0,92	5,9 0,62	3,1 0,48
2,8	10080				87 2,02	41,2 1,43	17,3 0,99	6,7 0,67	3,6 0,51
3,0	10800				113 2,17	46,6 1,53	19,5 1,06	7,5 0,71	4,1 0,55
3,5	12600				149 2,53	61,4 1,78	25,7 1,24	9,9 0,83	5,3 0,64
4,0	14400					77,9 2,04	32,6 1,41	12,6 0,95	6,7 0,73
4,5	16200					96,2 2,29	40,2 1,59	15,5 1,07	8,3 0,82
5,0	18000					116,2 2,55	48,5 1,77	18,7 1,19	10,0 0,92
6,0	21600					161,1 3,06	67,2 2,12	25,9 1,43	13,9 1,10
7,0	25200						88,6 2,48	34,2 1,66	18,3 1,28
8,0	28800						112,7 2,83	43,4 1,90	23,2 1,46
9	32400						139,3 3,18	53,6 2,14	28,7 1,65
10	36000							64,8 2,38	34,7 1,83
11	39600							77 2,61	41,1 2,01
12	43200							90,0 2,85	48,1 2,20
13	46800							104,0 3,09	55,6 2,38
15	50400								71,9 2,75
17	54000								92,1 3,11

Pressure loss for PP-R pipes SDR 7,4 with water temperature at 10° C

Flow rate		∅	∅	∅	∅	∅	∅	∅
I/s	kg/h	25x4,2	32x4,4	40x5,5	50x6,9	63x8,7	75x10,4	90x12,5
0,10	360	16,9 0,39	5,2 0,24					
0,15	540	33,8 0,59	10,2 0,35	Head loss in mm c.a./m Average speed in m/s				
0,20	720	55,4 0,79	16,7 0,47					
0,25	864	81,4 0,98	24,5 0,59					
0,30	1080	111,6 1,18	33,6 0,71	11,7 0,45				
0,35	1260	145,9 1,38	43,9 0,83	15,3 0,53				
0,40	1440	184,2 1,57	55,3 0,95	19,2 0,61	6,7 0,39			
0,45	1620	226,3 1,77	67,9 1,06	23,6 0,68	8,3 0,44			
0,50	1800	272,2 1,96	81,5 1,18	28,3 0,76	9,9 0,49			
0,55	1980	321,7 2,16	96,3 1,30	33,4 0,83	11,7 0,53			
0,60	2160		112,2 1,42	38,9 0,91	13,6 0,58			
0,65	2340		129,0 1,54	44,7 0,98	15,6 0,63	5,2 0,40		
0,70	2520		147,0 1,66	50,9 1,06	17,8 0,68	6,0 0,43		
0,75	2700		165,9 1,77	57,4 1,14	20,0 0,73	6,7 0,46		
0,80	2880		185,9 1,89	64,3 1,21	22,4 0,78	7,5 0,49		
0,85	3060		206,8 2,01	71,5 1,29	24,9 0,83	8,3 0,52		
0,90	3240		228,7 2,13	79,1 1,36	27,6 0,87	9,2 0,55		
1,00	3600			95,2 1,51	33,1 0,97	11,1 0,61	4,9 0,43	
1,20	4320			131,2 1,82	45,6 1,17	15,2 0,73	6,7 0,52	
1,40	5040			172,3 2,12	59,9 1,36	20,0 0,86	8,8 0,61	3,7 0,42
1,60	5760				75,8 1,55	25,2 0,98	11,1 0,69	4,7 0,48
1,80	6480				93,3 1,75	31,1 1,10	13,6 0,78	5,7 0,54
2,00	7200				112,5 1,94	2,00 1,22	16,4 0,87	6,9 0,60
2,20	7920				133,2 2,14	44,3 1,35	19,4 0,95	8,2 0,66
2,40	8640					51,6 1,47	22,7 1,04	9,5 0,72
2,60	9360					69,5 1,59	26,1 1,13	11,0 0,78

Flow rate		∅	∅	∅	∅	∅	∅	∅
I/s	kg/h	50x6,9	63x8,7	75x10,4	90x12,5	110x15,2	125x17,1	160x21,9
2,80	10080		67,9 1,71	29,8 1,21	12,5 0,84	4,6 0,56		
3,00	10800		76,7 1,84	33,6 1,30	14,1 0,90	5,4 0,60	2,9 0,46	
3,50	12600		100,9 2,14	44,2 1,52	18,6 1,05	7,1 0,70	3,8 0,54	
4,00	14400		128,0 2,45	56,0 1,73	23,5 1,21	8,9 0,80	4,8 0,62	
4,50	16200		158,0 2,76	69,1 1,95	29 1,36	11,0 0,90	5,9 0,69	
5,00	18000			83,4 2,17	35 1,51	13,3 1,00	7,1 0,77	2,2 0,47
5,50	19800			98,9 2,38	41,5 1,66	15,7 1,11	8,4 0,85	2,6 0,52
6,00	21600			115,6 2,60	48,4 1,81	18,4 1,21	9,8 0,93	3,0 0,57
6,50	23400				55,9 1,96	20,6 1,29	11,3 1,00	3,5 0,61
7,00	25200				63,8 2,11	24,2 1,41	12,9 1,08	4,0 0,66
7,50	27000				72,2 2,26	27,3 1,51	14,6 1,16	4,5 0,71
8,00	28800				81,0 2,41	30,7 1,61	16,3 1,24	5,0 0,75
9,00	32400				100,0 2,71	37,9 1,81	20,2 1,39	6,2 0,85
10,00	36000					45,8 2,01	24,4 1,54	7,5 0,94
11,00	39600					54,3 2,21	28,9 1,70	8,9 1,04
12,00	43200					63,5 2,41	33,8 1,85	10,4 1,13
13,00	46800					73,3 2,61	39,0 2,01	12,0 1,23
14,00	50400						44,5 2,16	13,6 1,32
15,00	54000						50,4 2,32	15,4 1,41
16,00	57600						56,6 2,47	17,1 1,50
17,00	61200						63,1 2,63	19,3 1,60
20,00	79200							25,9 1,89
30,00	108000							53,8 2,83
40,00	144000							
50,00	180000							
60,00	216000							

Pressure loss for PP-R pipes SDR 11 with water temperature at 10° C

Flow rate				Flow rate				Flow rate				Flow rate				Flow rate			
l/s		kg/h		l/s		kg/h		l/s		kg/h		l/s		kg/h		l/s		kg/h	
∅	∅	∅	∅	∅	∅	∅	∅	∅	∅	∅	∅	∅	∅	∅	∅	∅	∅	∅	∅
200x18,2	250x22,7	200x18,2	250x22,7	200x18,2	250x22,7	200x18,2	250x22,7	200x18,2	250x22,7	200x18,2	250x22,7	200x18,2	250x22,7	200x18,2	250x22,7	200x18,2	250x22,7	200x18,2	250x22,7
10,00	36000	1,46	0,50	15,00	54000	3,00	1,03	20,00	72000	5,02	1,72	45,00	162000	21,61	7,38	70,00	18000	16,39	2,13
		0,48	0,30			0,71	0,46			0,95	0,95			2,14	1,37				
11,00	39600	1,73	0,59	16,00	57600	3,37	1,16	25,00	90000	7,49	2,56	50,00	180000	26,14	8,92	75,00	21600	18,58	2,28
		0,52	0,33			0,76	0,49			1,19	0,76			2,38	1,52				
12,00	43200	2,02	0,69	17,00	61200	3,75	1,29	30,00	108000	10,40	3,56	55,00	12600	31,07	10,60	80,00	25200	20,88	2,43
		0,57	0,36			0,81	0,52			1,43	0,91			2,62	1,67				
13,00	46800	2,33	0,80	18,00	64800	4,16	1,43	35,00	126000	13,73	4,69	60,00	14400		12,40	90,00	18000	25,86	2,74
		0,62	0,40			0,86	0,55			1,66	1,06				1,82				
14,00	50400	2,65	0,91	19,00	68400	4,58	1,57	40,00	144000	17,47	5,97	66,00	16200		14,74				
		0,67	0,43			0,90	0,58			1,90	1,22				2,01				

4.7 Pressure Loss Fitting



















Description	Symbol	Coefficient of resistance (r)
Coupling pipe		0,25
90° Elbow		2,00
45° Elbow		0,60
Identical 90° Tee		1,80
Reduced 90° Tee		3,60
Identical 90° Tee		1,30
Reduced 90° Tee		2,60
Identical 90° Tee		4,20
Reduced 90° Tee		9,00
Identical 90° Tee		2,20
Reduced 90° Tee		5,00
Male threaded 90° Tee		0,80
Concentric reduction pipe up 2 dim.		0,55
Concentric reduction pipe up 3 dim.		0,85
Male threaded joint		0,40
Reduced male threaded joint		0,85
Male threaded elbow		2,20
Reduced male threaded elbow		3,50

Figure 4

4.8 Linear Deformation under Heat Influence

The calculation of the linear deformation is based on the laying temperature. The following example gives you an idea of how to calculate.

Example for a pipe length of 8 m:

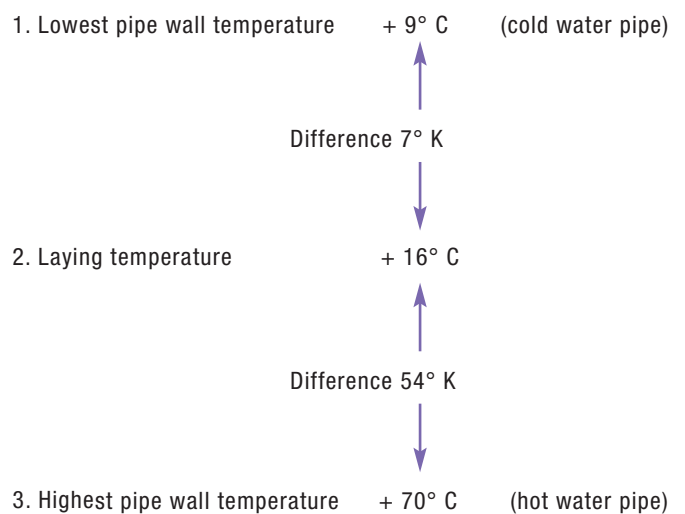

To 1. Shortening of the pipe: $8 \text{ m} \times 7^\circ \times 0,03 = 1,68 \text{ mm}$

To 3. Extension of the pipe: $8 \text{ m} \times 54^\circ \times 0,03 = 12,96 \text{ mm}$

Diagram and chart to determine the temperature-dependent linear expansion of PP-R and PP-RCT monolayer pipes.

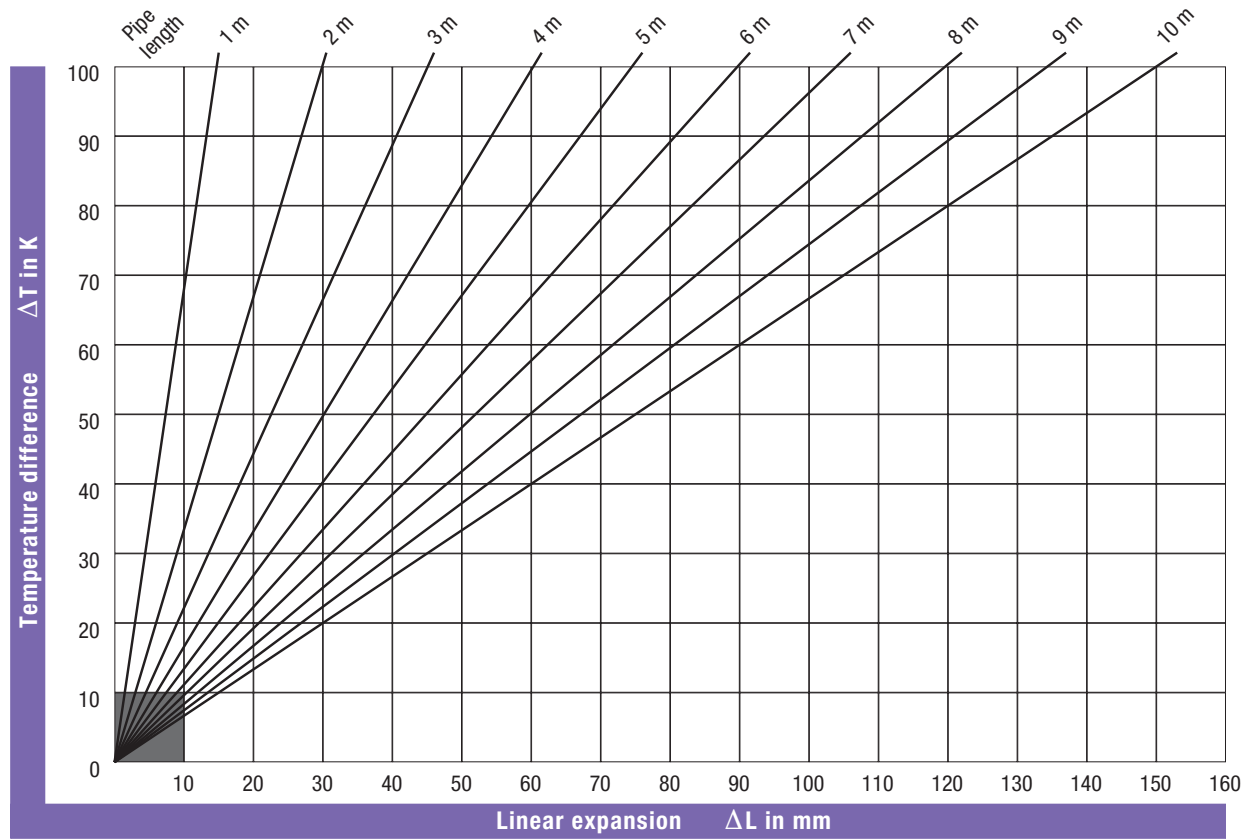

Figure 5

Pipe length	Temperature difference ΔT in K									
	10	20	30	40	50	60	70	80	90	100
0,1 m	0,15	0,30	0,45	0,60	0,75	0,90	1,05	1,20	1,35	1,50
0,2 m	0,30	0,60	0,90	1,20	1,50	1,80	2,10	2,40	2,70	3,00
0,3 m	0,45	0,90	1,35	1,80	2,25	2,70	3,15	3,60	4,05	4,50
0,4 m	0,60	1,20	1,80	2,40	3,00	3,60	4,20	4,80	5,40	6,00
0,5 m	0,75	1,50	2,25	3,00	3,75	4,50	5,25	6,00	6,75	7,50
0,6 m	0,90	1,80	2,70	3,60	4,50	5,40	6,30	7,20	8,10	9,00
0,7 m	1,05	2,10	3,15	4,20	5,25	6,30	7,35	8,40	9,45	10,50
0,8 m	1,20	2,40	3,60	4,80	6,00	7,20	8,40	9,60	10,80	12,00
0,9 m	1,35	2,70	4,05	5,40	6,75	8,10	9,45	10,80	12,15	13,50
1,0 m	1,50	3,00	4,50	6,00	7,50	9,00	10,50	12,00	13,50	15,00
2,0 m	3,00	6,00	9,00	12,00	15,00	18,00	21,00	24,00	27,00	30,00
3,0 m	4,50	9,00	13,50	18,00	22,50	27,00	31,50	36,00	40,50	45,00
4,0 m	6,00	12,00	18,00	24,00	30,00	36,00	42,00	48,00	54,00	60,00
5,0 m	7,50	15,00	22,50	30,00	37,50	45,00	52,50	60,00	67,50	75,00
6,0 m	9,00	18,00	27,00	36,00	45,00	54,00	63,00	72,00	81,00	90,00
7,0 m	10,50	21,00	31,50	42,00	52,50	63,00	73,50	84,00	94,50	105,00
8,0 m	12,00	24,00	36,00	48,00	60,00	72,00	84,00	96,00	108,00	120,00
9,0 m	13,50	27,00	40,50	54,00	67,50	81,00	94,50	108,00	121,50	135,00
10,0 m	15,00	30,00	45,00	60,00	75,00	90,00	105,00	120,00	135,00	150,00

Figure 5/1

Diagram and chart to determine the temperature dependent linear expansion of multilayer pipes with inlaid fiberglass layer

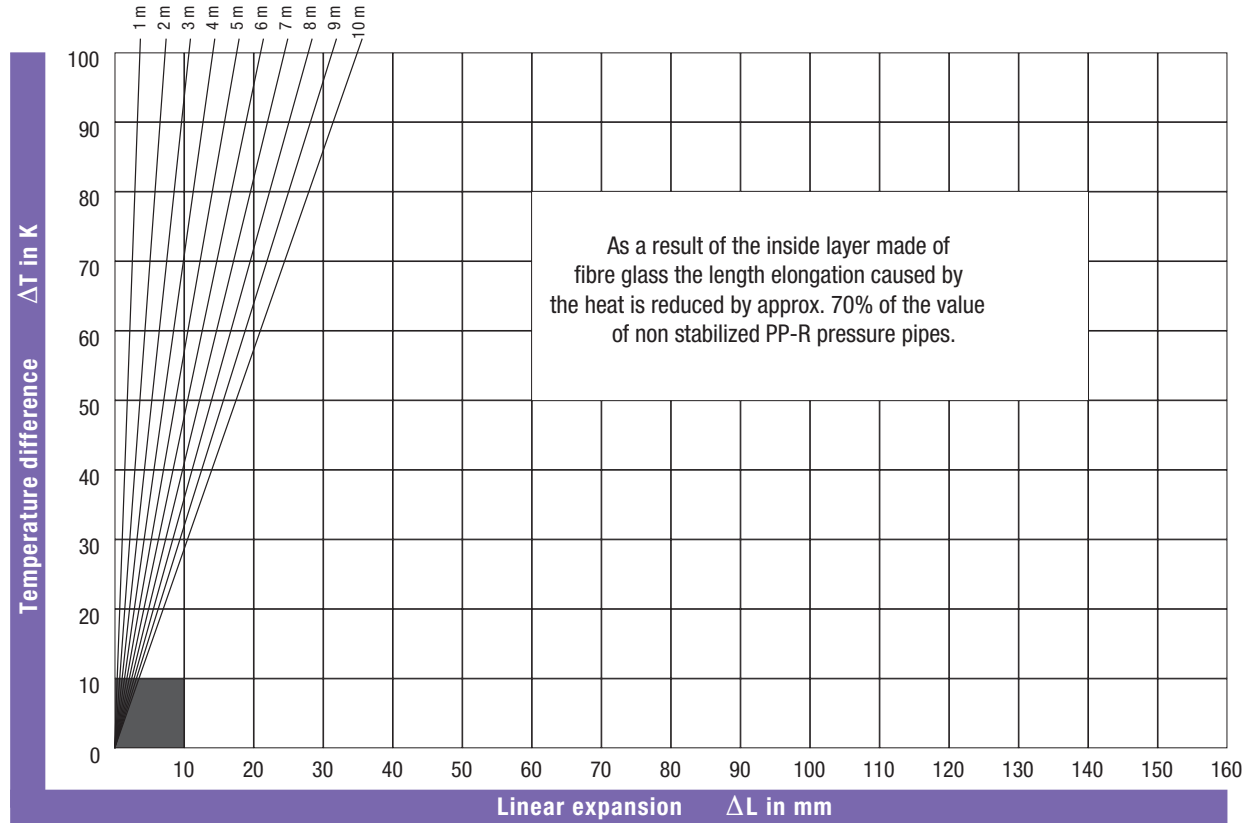

Figure 6

Pipe length	Temperature difference ΔT in K									
	10	20	30	40	50	60	70	80	90	100
0,1 m	0,04	0,07	0,11	0,14	0,18	0,21	0,25	0,28	0,32	0,35
0,2 m	0,07	0,14	0,21	0,28	0,35	0,42	0,49	0,56	0,63	0,70
0,3 m	0,11	0,21	0,32	0,42	0,53	0,63	0,74	0,84	0,95	1,05
0,4 m	0,14	0,28	0,42	0,56	0,70	0,84	0,98	1,12	1,26	1,40
0,5 m	0,18	0,35	0,53	0,70	0,88	1,05	1,23	1,40	1,58	1,75
0,6 m	0,21	0,42	0,63	0,84	1,05	1,26	1,47	1,68	1,89	2,10
0,7 m	0,25	0,49	0,74	0,98	1,23	1,47	1,72	1,96	2,21	2,45
0,8 m	0,28	0,56	0,84	1,12	1,40	1,68	1,96	2,24	2,52	2,80
0,9 m	0,32	0,63	0,95	1,26	1,58	1,89	2,21	2,52	2,84	3,15
1,0 m	0,35	0,70	1,05	1,40	1,75	2,10	2,45	2,80	3,15	3,50
2,0 m	0,70	1,40	2,10	2,80	3,50	4,20	4,90	5,60	6,30	7,00
3,0 m	1,05	2,10	3,15	4,20	5,25	6,30	7,35	8,40	9,45	10,50
4,0 m	1,40	2,80	4,20	5,60	7,00	8,40	9,80	11,20	12,60	14,00
5,0 m	1,75	3,50	5,25	7,00	8,75	10,50	12,25	14,00	15,75	17,50
6,0 m	2,10	4,20	6,30	8,40	10,50	12,60	14,70	16,80	18,90	21,00
7,0 m	2,45	4,90	7,35	9,80	12,25	14,70	17,15	19,60	22,05	24,50
8,0 m	2,80	5,60	8,40	11,20	14,00	16,80	19,60	22,40	25,20	28,00
9,0 m	3,15	6,30	9,45	12,60	15,75	18,90	22,05	25,20	28,35	31,50
10,0 m	3,50	7,00	10,50	14,00	17,50	21,00	24,50	28,00	31,50	35,00

Linear expansion ΔL in mm

Figure 6/1

4.9 Distance Between the Supporting Points

The type and number of the pipe fixings, depend on the type of structure and on the longitudinal expansion. The fixed points must divide the pipe into sections in which contraction or expansion would take place; at any rate expansion must never occur on the inserts or on the fillings. The different pipe sections are maintained by sliding hinges. The distance between those fixings, i.e. the

distance between the supporting points, depend on the working conditions and on the weight of the pipes (including that of the fluid which is conveyed). On a practical point of view, the distance between the supporting points reported in the following tables have been found to be valid.

Distance between the supporting points in cm. at different temperatures

Ø mm.	20° C	30° C	40° C	50° C	60° C	70° C	80° C
16	60	60	60	55	45	45	40
20	65	65	60	60	60	55	50
25	75	75	70	70	65	60	55
32	90	90	85	85	80	75	70
40	110	110	105	100	95	90	85
50	125	120	115	110	105	100	90
63	140	135	130	125	120	115	105
75	155	150	145	135	130	125	115
90	165	160	155	145	140	130	120
110	185	180	170	165	155	150	140
125	190	185	180	170	160	155	150

Figure 7 Distance for K-Pipe PN 20

Ø mm.	20° C	30° C	40° C	50° C	60° C		
20	60	55	50	45	40		
25	75	70	65	60	55		
32	90	85	75	70	65		
40	100	95	90	85	75		
50	120	115	105	100	90		
63	140	130	120	110	100		
75	150	145	135	125	115		
90	160	155	150	145	130		
110	180	170	160	155	140		
125	190	185	175	165	150		
160	200	195	185	175	160		
200	245	235	225	245	205		
250	275	265	255	245	235		
315	290	280	270	260	250		

Figure 8 Distance for K-Pipe PN 16

Distance between the supporting points in cm. at different temperatures

Ø mm.	20° C	30° C	40° C	50° C	60° C	70° C	80° C
20	100	90	85	85	80	70	65
25	105	100	95	90	85	80	75
32	120	115	110	105	100	95	90
40	130	125	120	115	110	105	100
50	150	145	140	135	130	125	120
63	160	155	150	145	140	135	130
75	180	175	170	165	160	155	145
90	190	185	180	175	170	165	150
110	200	195	190	180	175	170	160
125	220	210	205	195	185	175	165
160	220	210	205	195	185	175	165
200	245	235	230	220	210	200	190
250	275	265	255	245	235	225	210

Figure 9 Distance for K-Fiber Pipe PN 20

Ø mm.	20° C	30° C	40° C	50° C	60° C	70° C	80° C
20	80	80	75	75	70	60	55
25	95	90	85	80	75	70	65
32	110	105	100	95	90	85	80
40	120	115	110	105	100	95	90
50	140	135	130	125	120	115	110
63	150	145	140	135	130	125	120
75	165	160	155	150	145	140	130
90	175	170	165	160	155	150	135
110	185	180	175	165	160	155	145
125	205	195	190	180	170	160	150
160	205	195	190	180	170	160	150
200	230	220	210	200	190	180	170
250	250	240	230	220	210	200	185

Figure 10 Distance for K-Fiberclima Pipe PN 16

Linear extension compension of pp-r pipes

The linear extension of a PP-R pipe can in most of the cases be compensated by a change in direction. With this see to free mobility of the piping in axial direction. Should linear extension compensa-tion by directational change not be possible the fitting in of an expansion bend is required. Axial bellow expansion joints are mostly unfit and uneconomical for optimum resiliency of the pipe the size bending limb is important this calculated by the opposite formula.

The figures 11 and 12 show the effects of the linear deformation and its compension with regard bending limbs L_s make sure to chose the correct locating points.

$$L_s = C \times \sqrt{d \times \Delta L} \quad (\text{mm})$$

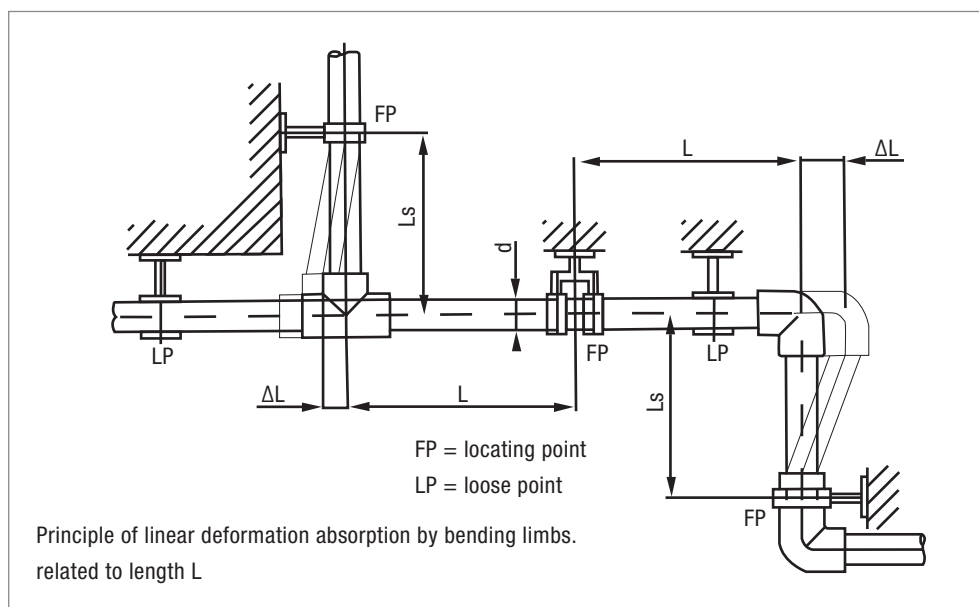

- L_s = Length of bending limb (mm)
- d = Outside pipe diameter (mm)
- ΔL = Linear deformation (mm)
- C = Material depending constant for pp-r = 20

Figure 11

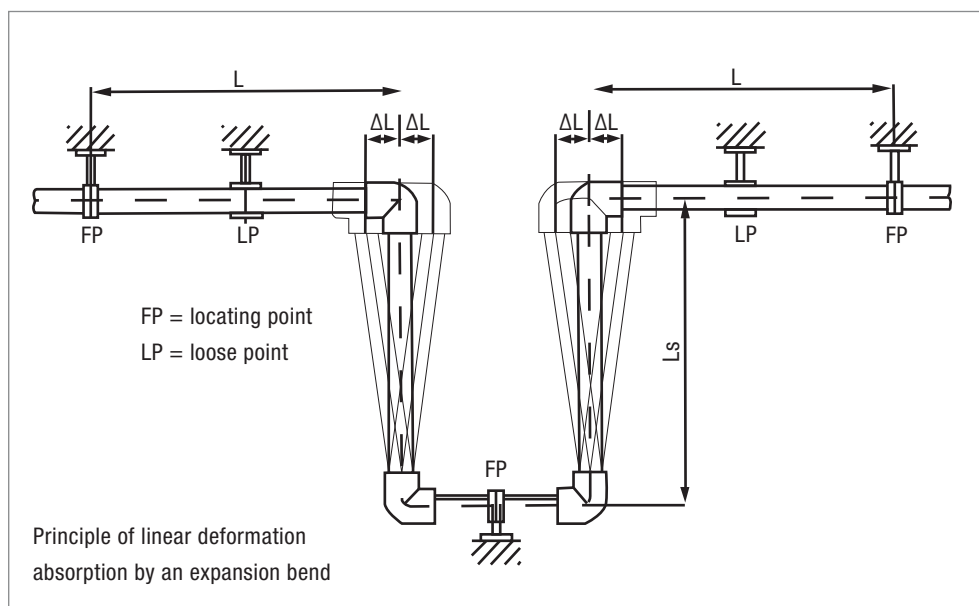

Figure 12

Construction of expansion bends:

Expansion bends can easily be made right at the site.
 Beside the required pipe length 4 elbows (AQ090)
 To construct an expansion bend, the bending limb L is calculated in dependence on the linear deformation ΔL . As standard value, the L value given in the fig. 14 diagram can be used.
 Spacing B should be at least $10 \times d$.
 Expansion bend, made of **K-Aqua** pipe and 90° elbow. (Fig. 13)

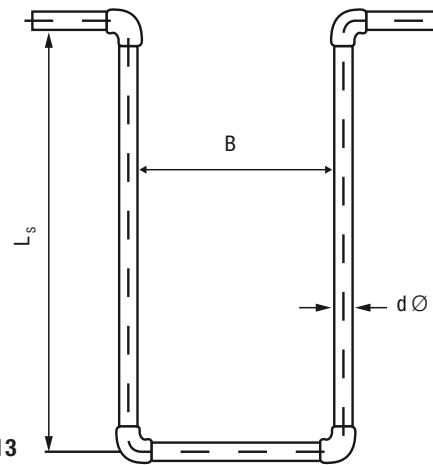

Figure 13

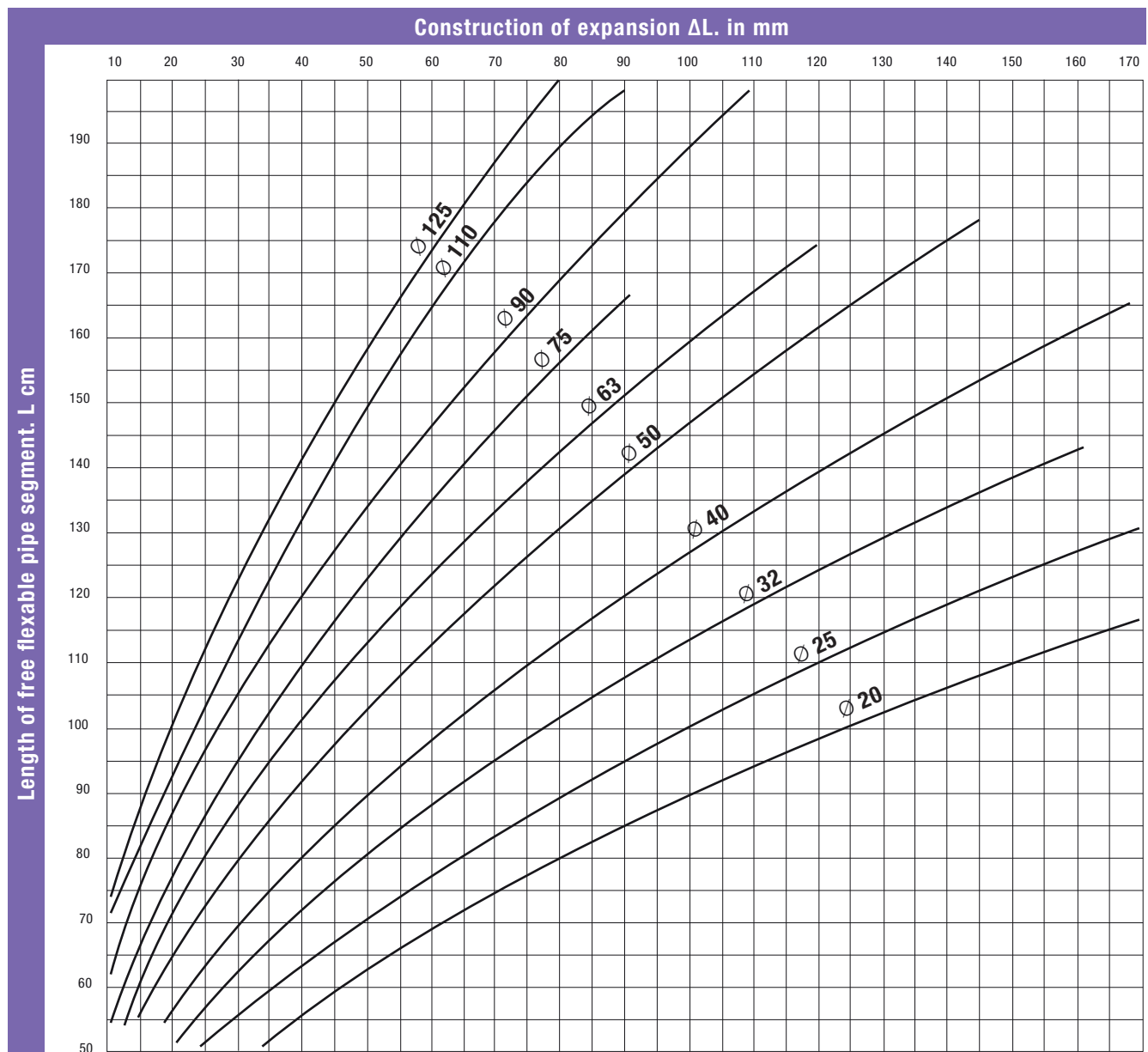

Figure 14

4.10 Length Variation of K-Aqua Pipes Due to Heat (Thermal Stress)

K-Aqua pipes are subject to a relatively high thermal expansion whenever they are exposed to temperature variations.

The longitudinal thermal expansion of these pipes is about 11 times more important than in steel pipes.

This fact must be taken into account during the starting-up phase. Therefore, as early as in the design phase, all the alternatives regarding the position or the path of the pipes must be thoroughly examined in order to compensate thermal expansion in the various pipe sections.

The coefficient of longitudinal thermal expansion for **K-Aqua** monolayer pipes is:

$$\epsilon t = 1,5 \times 10^{-4} \text{ (K}^{-1}\text{)}.$$

K-Fiber pipes

$$\epsilon t = 0.35 \times 10^{-4} \text{ (K}^{-1}\text{)}$$

Δl = Linear extension in (mm)

ϵt = Thermal expansion (mm)
coefficient in (m °C)

L = Pipe length (m)

Δt = Temperature difference (°K)

The linear deformation of a pipe is thus calculated according to the following formula:

$$\Delta l = \epsilon t \times L \times \Delta t \text{ (mm)}$$

4.11 System Testing

The testing of the water supply system is carried out through tests and checks during the installation (for the parts that are no longer accessible once the work is completed) and tests and final checks for the implementation of contractual obligations.

The cold hydraulic test pressure prescribed by European Standards CEN TR 12108 and EN 806-4 (Procedure C) is carried out according to the following procedure.

1. Fill the system slowly to vent it (do not fully tighten the highest plugs that will be closed when the water will come out with a continuous jet).
2. Bring the pressure up to 15 bar and repeat the process 2 more times every 10 minutes.
3. Measure the pressure after the first 30 minutes.
4. Read the pressure after another 30 minutes (1 hour). If the difference is less than 0,6 bar, there is no pressure drop and the test can be continued with the same pressure for 2 more hours.
5. In these last 2 hours the pressure must not drop more than 0,2 bar.
6. The results of this test shall be recorded.

It is also important to perform:

- Cold water supply test with cold water bleed from all utilities to check the flow rate and pressure.
- Hot water supply test with hot water bleed from all utilities to check the flow rate and pressure.
- Noise level check in accordance with the regulations in force.

N.B.:

Testing pressure shall be reduced if radiators, taps or valves are present.





5	Storage & Handling	Page
	5.1 Transportation	62
	5.2 Packaging	62
	5.3 Handling	62
	5.4 Dispose of waste materials	63



5.1 Transportation

During the various working phases, the surface of **K-Aqua** may be exposed nicks or cuts. In order to avoid dangerous situations due to possible cuts, all handling must be made with the upmost care. It is strongly prohibited to install damaged pipes or fittings.

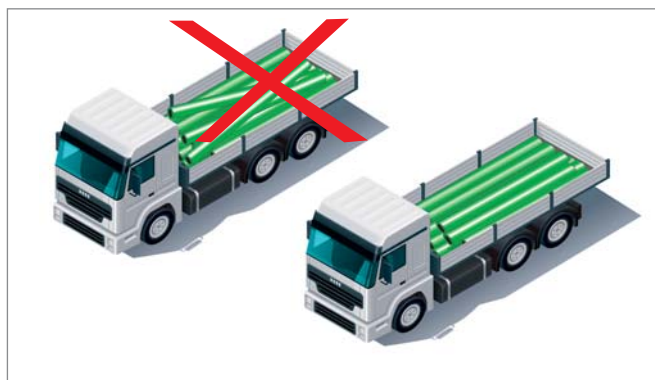

5.2.2 Fittings

Fittings are packed in plastic bags, plastic bags are packed in carton boxes:

Carton box	Box dimensions LxBxH (cm)	Boxes/pallet
1	40x30x22	32



5.2 Packaging

5.2.1 Pipes

Pipes are packed in bundles, bundles are packed in foil. Pipes can be identified by the marking on the pipe.







K-Aqua-Storage & Handling

5.3 Handling

Thanks to the material properties of polypropylene, the pipes and fittings can be stored for a long time under varying temperatures. The storage of pipes and fittings must be in accordance with the following conditions:

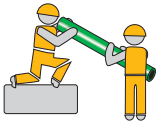
1. The pipes should be supported along their full length.
2. Bending of the pipes is to be avoided.
3. The material becomes sensitive to impact at low temperatures and in particular at temperatures below 0° C. For this reason knocks and similar impacts are to be avoided under these conditions.
4. High-polymer materials are sensitive to UV radiation. For this reason the **K-Aqua** material should also be protected against the effects of UV radiation.

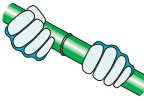
Suggestions for the correct treatment of pipe systems

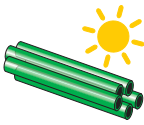
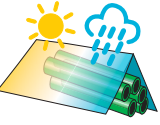
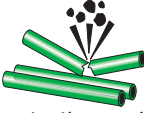
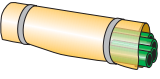
 No	 Yes
 Avoid hard knocks or impacts at the end of a pipe	 Put pipes down carefully
 Do not use pipes which are damaged or cracked at the interface	 Cut pipes only with sharp tools
 Do not twist either pipe or fitting after joining together	 Alignment corrections of up to 5 relative to the axis of the pipe can be carried out immediately after joining
 Do not expose to UV-radiation for any extended period of time	 Store protected from sun and rain
 Provide protection against hard impacts and falling stones on the site	 Cover pipes at risk to prevent damage

5.4 Dispose of Waste Materials

Dispose waste material separated according to the regulations. PP pipes and fittings are recyclable.

Transition fittings	Recyclable, after separation of PP and brass
Gaskets	general waste
Cardboard boxes	recyclable
Plastic bags	recyclable
Chips	general waste
Wipes	general waste

International regulation on drinking water for human consumption prevents to apply recycled material in the production process for water supply systems.



6

Products

Page

6.1 Pipes	67 - 71
6.2 Fittings	73 - 81
6.3 Transition fittings	83 - 87
6.4 Weld-in saddles	89 - 91
6.5 Valves	93 - 96
6.6 Accessories	97 - 99
6.7 Tools	101 - 105



Pipes

Page

K-Pipe PN 10	68
K-Pipe PN 16	68
K-Pipe PN 20 PP-RCT	69
K-Pipe PN 20 PP-R	69
K-Fiberclima Pipe PN 16	70
K-Fiber Pipe PN 20	70
K-Pipe „purple“ PN 10	71
K-Fiber UV Pipe PN 20	71

„K Pipe PN 10” SDR 11 – S 5 (20° C/1,0 MPa – 70° C/0,5 MPa), length 4 meter



Code	D	DN	Di	S min.	Pack.	Weight kg/m	Water capacity l/m
AQ10020	20	15	16,2	1,9	100	0,11	0,21
AQ10025	25	20	20,4	2,3	100	0,16	0,33
AQ10032	32	25	26,2	2,9	60	0,26	0,54
AQ10040	40	32	32,6	3,7	40	0,41	0,83
AQ10050	50	40	40,8	4,6	20	0,64	1,31
AQ10063	63	50	51,4	5,8	20	1,01	2,07
AQ10075	75	-	61,4	6,8	8	1,41	2,96
AQ10090	90	65	73,6	8,2	8	2,03	4,25
AQ100110	110	80	90,0	10,0	8	3,01	6,36
AQ100125	125	100	102,2	11,4	4	3,91	8,20
AQ100160	160	125	130,8	14,6	4	6,38	13,43
AQ100200	200	160	163,6	18,2	4	9,76	21,01
AQ100250	250	200	204,6	22,7	4	15,00	32,86

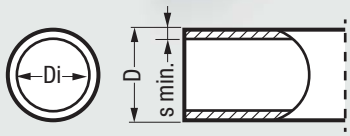

Material: PP-R
 Colour: green with 1 blue stripe
 Standards: DIN EN ISO 15874
 DIN 8077 / 8078

„K Pipe PN 16” SDR 11 – S 5 (20° C/1,6 MPa – 70° C/0,8 MPa), length 4 meter



Code	D	DN	Di	S min.	Pack.	Weight kg/m	Water capacity l/m
AQ16032	32	25	26,2	2,9	60	0,26	0,54
AQ16040	40	32	32,6	3,7	40	0,41	0,83
AQ16050	50	40	40,8	4,6	20	0,64	1,31
AQ16063	63	50	51,4	5,8	20	1,01	2,07
AQ16075	75	-	61,4	6,8	8	1,41	2,96
AQ16090	90	65	73,6	8,2	8	2,03	4,25
AQ160110	110	80	90,0	10,0	8	3,01	6,36
AQ160125	125	100	102,2	11,4	4	3,91	8,20
AQ160160	160	125	130,8	14,6	4	6,38	13,43
AQ160200	200	160	163,6	18,2	4	9,76	21,01
AQ160250	250	200	204,6	22,7	4	15,0	32,86

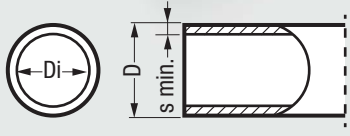

Material: PP-RCT
 Colour: green
 Standards: DIN EN ISO 15874
 DIN 8077 / 8078

„K Pipe PN 20” SDR 7,4 – S 3,2 (20° C/2,0 MPa – 70° C/1,0 MPa), length 4 meter

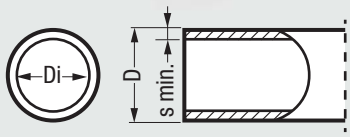
Code	D	DN	Di	S min.	Pack.	Weight kg/m	Water capacity l/m
AQ20020	20	15	14,4	2,8	100	0,16	0,16
AQ20025	25	20	18,0	3,5	100	0,23	0,25
AQ20032	32	25	23,2	4,4	60	0,37	0,42
AQ20040	40	32	29,0	5,5	40	0,57	0,66
AQ20050	50	40	36,2	6,9	20	0,88	1,03
AQ20063	63	50	45,8	8,6	20	1,39	1,63
AQ20075	75	-	54,4	10,3	8	1,98	2,31
AQ20090	90	65	65,4	12,3	8	2,83	3,32
AQ200110	110	80	79,8	15,1	8	4,25	4,97
AQ200125	125	100	90,8	17,1	4	5,41	6,47
AQ200160	160	125	116,2	21,9	4	9,09	10,60
AQ200200	200	160	145,2	27,4	4	13,70	16,55
AQ200250	250	200	181,6	34,2	4	21,25	25,89

Material: PP-RCT
 Colour: green with 1 red stripe
 Standards: DIN EN ISO 15874
 DIN 8077 / 8078

„K Pipe PN 20” SDR 6 – S 2,5 (20° C/2,0 MPa – 70° C/1,0 MPa), length 4 meter



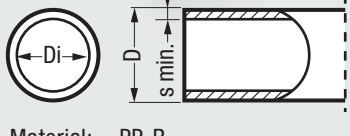

Code	D	DN	Di	S min.	Pack.	Weight kg/m	Water capacity l/m
AQ200P20*	20	12	13,2	3,4	100	0,18	0,14
AQ200P25*	25	15	16,6	4,2	100	0,28	0,22
AQ200P32*	32	20	21,2	5,4	60	0,46	0,35
AQ200P40*	40	25	26,6	6,7	40	0,68	0,56
AQ200P50*	50	32	33,2	8,3	20	1,09	0,87
AQ200P63*	63	40	42,0	10,5	20	1,60	1,39
AQ200P75	75	50	50,0	12,5	8	2,50	1,96
AQ200P90	90	-	60,0	15,0	8	3,30	2,83
AQ200P110	110	65	73,2	18,3	8	5,00	4,21
AQ200P125	125	80	83,2	20,8	4	6,50	5,46

Material: PP-R
 Colour: green with 1 red stripe
 Standards: DIN EN ISO 15874
 DIN 8077 / 8078

* pipes can be delivered in 5,80 meter length on special request with product code AQ258P+dimension

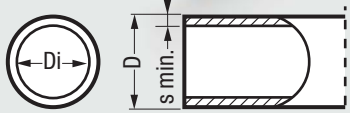
„K-Fiberclima Pipe PN 16“ SDR 11 – S 5 (20° C/1,6 MPa – 70° C/0,8 MPa), length 4 meter





Code	D	DN	Di	S min.	Pack.	Weight kg/m	Water capacity l/m
AQ160F20	20	15	14,4	2,8*	100	0,16	0,16
AQ160F25	25	20	18,0	3,5*	100	0,25	0,25
AQ160F32	32	25	26,2	2,9	60	0,28	0,54
AQ160F40	40	32	32,6	3,7	40	0,43	0,83
AQ160F50	50	40	40,8	4,6	20	0,67	1,31
AQ160F63	63	50	51,4	5,8	20	1,04	2,07
AQ160F75	75	-	61,4	6,8	8	1,44	2,96
AQ160F90	90	65	73,6	8,2	8	2,08	4,25
AQ160F110	110	80	90,0	10,0	8	3,10	6,36
AQ160F125	125	100	102,2	11,4	4	4,02	8,20
AQ160F160	160	125	130,8	14,6	4	6,50	13,43
AQ160F200	200	160	163,6	18,2	4	10,09	21,01
AQ160F250	250	200	204,6	22,7	4	15,01	32,86

Material: PP-RCT GF
 Colour: green with 4 blue stripes
 Standards: DIN EN ISO 15874

* SDR 7,4 - S 3,2

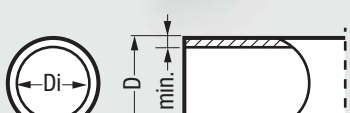
„K-Fiber Pipe PN 20“ SDR 7,4 – S 3,2 (20° C/2,0 MPa – 70° C/1,0 MPa), length 4 meter

Code	D	DN	Di	S min.	Pack.	Weight kg/m	Water capacity l/m
AQ200F20	20	15	14,4	2,8	100	0,16	0,16
AQ200F25	25	20	18,0	3,5	100	0,25	0,25
AQ200F32	32	25	23,2	4,4	60	0,39	0,42
AQ200F40	40	32	29,0	5,5	40	0,59	0,66
AQ200F50	50	40	36,2	6,9	20	0,91	1,03
AQ200F63	63	50	45,8	8,6	20	1,45	1,63
AQ200F75	75	-	54,4	10,3	8	2,06	2,31
AQ200F90	90	65	65,4	12,3	8	2,94	3,32
AQ200F110	110	80	79,8	15,1	8	4,36	4,97
AQ200F125	125	100	90,8	17,1	4	5,61	6,47
AQ200F160	160	125	116,2	21,9	4	9,09	10,60
AQ200F200	200	160	145,2	27,4	4	14,23	16,55
AQ200F250	250	200	181,6	34,2	4	22,08	25,89

Material: PP-RCT GF
 Colour: green with 4 red stripes
 Standards: DIN EN ISO 15874

„K Pipe purple PN 10” SDR 11 – S 5 (20° C/1,0 MPa – 70° C/0,5 MPa), length 4 meter

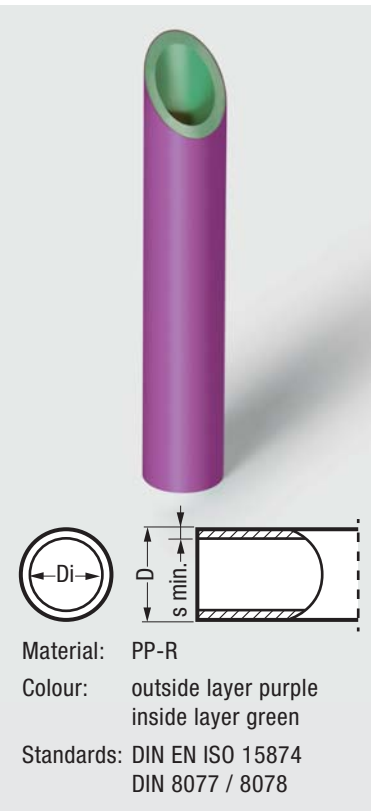

Code	D	DN	Di	S min.	Pack.	Weight kg/m	Water capacity l/m
AQ100L20	20	15	16,2	1,9	100	0,11	0,21
AQ100L25	25	20	20,4	2,3	100	0,16	0,33
AQ100L32	32	25	26,2	2,9	60	0,26	0,54
AQ100L40	40	32	32,6	3,7	40	0,41	0,83
AQ100L50	50	40	40,8	4,6	20	0,64	1,31
AQ100L63	63	50	51,4	5,8	20	1,01	2,07
AQ100L75	75	-	61,4	6,8	8	1,41	2,96
AQ100L90	90	65	73,6	8,2	8	2,03	4,25
AQ100L110	110	80	90	10,0	8	3,01	6,36
AQ100L125	125	100	102,2	11,4	4	3,91	8,20
AQ100L160	160	125	130,8	14,6	4	6,38	13,43

„K-Fiber UV Pipe PN 20” SDR 7,4 – S 3,2 (20° C/2,0 MPa – 70° C/1,0 MPa), length 4 meter

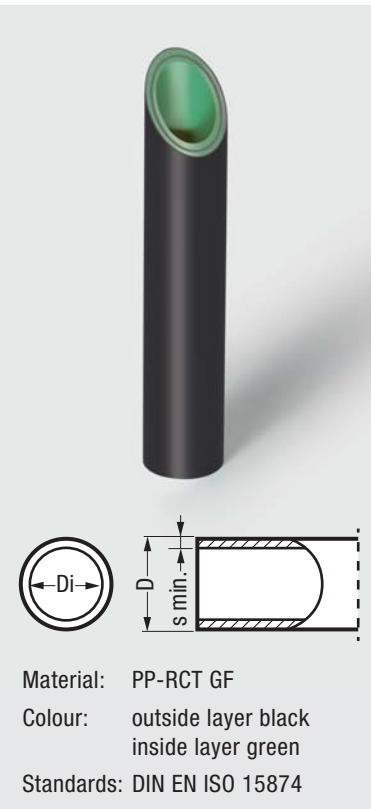

Code	D	DN	Di	S min.	Pack.	Weight kg/m	Water capacity l/m
AQ200FUV20	20	15	14,4	2,8	100	0,16	0,16
AQ200FUV25	25	20	18,0	3,5	100	0,25	0,25
AQ200FUV32	32	25	23,2	4,4	60	0,39	0,42
AQ200FUV40	40	32	29,0	5,5	40	0,59	0,66
AQ200FUV50	50	40	36,2	6,9	20	0,91	1,03
AQ200FUV63	63	50	45,8	8,6	20	1,45	1,63
AQ200FUV75	75	-	54,4	10,3	8	2,06	2,31
AQ200FUV90	90	65	65,4	12,3	8	2,94	3,32
AQ200FUV110	110	80	79,8	15,1	8	4,36	4,97
AQ200FUV125	125	100	90,8	17,1	4	5,61	6,47
AQ200FUV160	160	125	116,2	21,9	4	9,09	10,60



Fittings

Page

Elbow 45°	74
Elbow 90°	75
Socket	75
Cap	76
Reducing bush	77
Tee	78
Reducing tee	79
Flange adaptor	80
Cross over	80
Electrofusion socket	81

Elbow 45°

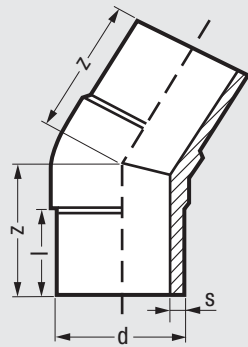
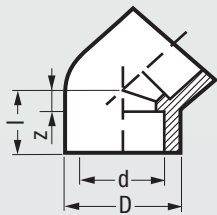

Code	d	D	l	z	s	kg	Pack.
AQ04520	20	29	21	6	-	0,02	300
AQ04525	25	35	24	8	-	0,02	200
AQ04532	32	44	29	10	-	0,05	100
AQ04540	40	52	32	11	-	0,06	80
AQ04550	50	65	37	13	-	0,10	54
AQ04563	63	84	44	16	-	0,21	24
AQ04575	75	99	50	20	-	0,32	20
AQ04590	90	120	58	25	-	0,58	10
AQ045110	110	148	69	32	-	0,98	4
AQ045125	125	165	78	37	-	1,53	2
SDR 11*							
AQ045160	160	160	103	150	14,6	1,99	1
AQ045200	200	200	117	195	18,2	4,31	1
AQ045250	250	250	150	208	22,7	7,85	1

* SDR 11 jointing techniques: butt-fusion or electrofusion welding

Elbow 90°

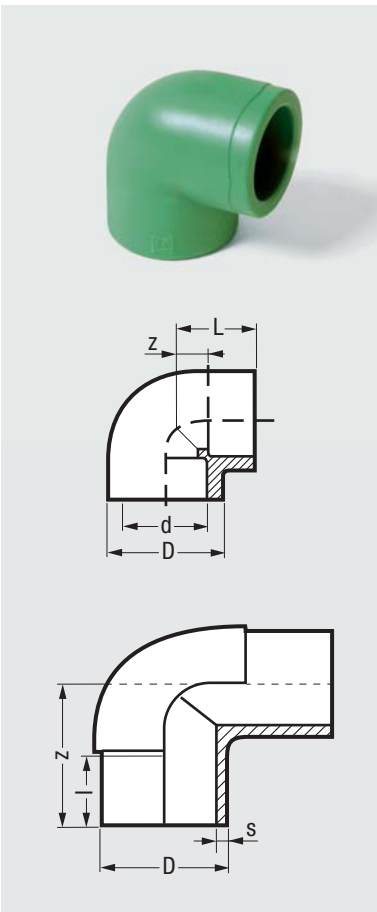

Code	d	D	L	l	z	s	kg	Pack.
AQ09020	20	29	27	-	14	-	0,02	300
AQ09025	25	35	31	-	16	-	0,02	180
AQ09032	32	44	37	-	20	-	0,05	100
AQ09040	40	52	44	-	23	-	0,07	80
AQ09050	50	65	52	-	28	-	0,14	30
AQ09063	63	84	62	-	34	-	0,27	24
AQ09075	75	101	71	-	41	-	0,44	15
AQ09090	90	120	83	-	50	-	0,79	6
AQ090110	110	148	99	-	62	-	1,30	4
AQ090125	125	165	125	-	84	-	2,17	2
SDR 11*								
AQ090160	160	160	-	101	213	14,6	3,02	1
AQ090200	200	200	-	116	255	18,2	5,50	1
AQ090250	250	250	-	172	295	22,7	9,14	1

* SDR 11 jointing techniques: butt-fusion or electrofusion welding

Socket

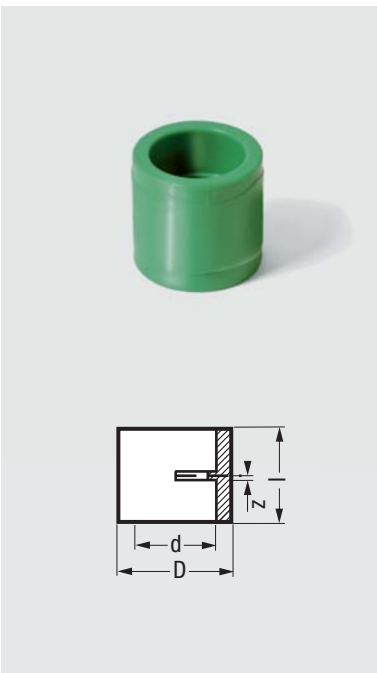

Code	d	D	l	z	kg	Pack.
AQ27020	20	29	34	5	0,01	500
AQ27025	25	35	37	5	0,02	300
AQ27032	32	44	41	5	0,03	160
AQ27040	40	52	46	5	0,05	100
AQ27050	50	65	52	5	0,07	80
AQ27063	63	84	60	5	0,13	44
AQ27075	75	99	65	5	0,20	36
AQ27090	90	120	76	10	0,35	18
AQ270110	110	148	80	6	0,57	10
AQ270125	125	160	102	7	0,90	4

Cap

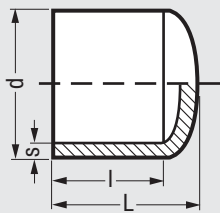
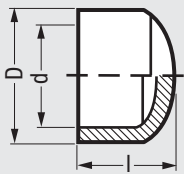

Code	d	D	l	L	s	kg	Pack.
AQ30120	20	29	25	-	-	0,01	600
AQ30125	25	34	28	-	-	0,01	400
AQ30132	32	43	32	-	-	0,02	260
AQ30140	40	52	36	-	-	0,03	160
AQ30150	50	65	41	-	-	0,06	160
AQ30163	63	79	48	-	-	0,09	100
AQ30175	75	99	54	-	-	0,18	48
AQ30190	90	120	66	-	-	0,35	21
AQ301110	110	148	79	-	-	0,59	15
AQ301125	125	162	87	-	-	0,85	4
SDR 11*							
AQ301160	160	-	117	145	14,6	1,20	1
AQ301200	200	-	145	175	18,2	2,14	1
AQ301250	250	-	155	235	22,7	3,21	1

* SDR 11 jointing techniques: butt-fusion or electrofusion welding

Reducing bush

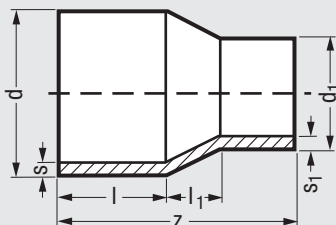
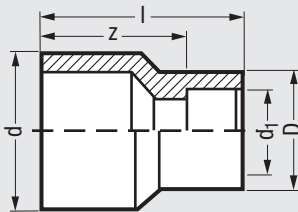

Code	d	d ₁	D	l	z	l ₁	s	s ₁	kg	Pack.
AQ2432520	25	20	29	36	22	-	-	-	0,01	420
AQ2433220	32	20	29	37	23	-	-	-	0,02	340
AQ2433225	32	25	34	39	23	-	-	-	0,02	320
AQ2434020	40	20	34	43	28	-	-	-	0,02	220
AQ2434025	40	25	34	43	27	-	-	-	0,02	200
AQ2434032	40	32	43	45	27	-	-	-	0,03	180
AQ2435020	50	20	43	51	36	-	-	-	0,04	180
AQ2435025	50	25	43	51	35	-	-	-	0,04	160
AQ2435032	50	32	43	51	33	-	-	-	0,05	140
AQ2435040	50	40	52	53	33	-	-	-	0,05	140
AQ2436320	63	20	34	56	42	-	-	-	0,08	75
AQ2436325	63	25	34	56	40	-	-	-	0,08	85
AQ2436332	63	32	43	58	40	-	-	-	0,08	90
AQ2436340	63	40	52	60	40	-	-	-	0,08	60
AQ2436350	63	50	65	63	40	-	-	-	0,09	65
AQ2437550	75	50	65	67	44	-	-	-	0,12	60
AQ2437563	75	63	80	71	44	-	-	-	0,15	38
AQ2439063	90	63	80	78	51	-	-	-	0,17	24
AQ2439075	90	75	99	81	51	-	-	-	0,23	36
AQ24311063	110	63	80	88	60	-	-	-	0,32	14
AQ24311075	110	75	100	90	60	-	-	-	0,37	14
AQ24311090	110	90	110	93	61	-	-	-	0,45	14
AQ243125110	125	110	151	92	57	-	-	-	0,68	8
SDR 11*										
AQ243160110	160	110	-	103	315	124	14,6	11,4	1,68	1
AQ243200160	200	160	-	118	240	21	18,2	14,6	2,18	1

* SDR 11 jointing techniques: butt-fusion or electrofusion welding

Tee

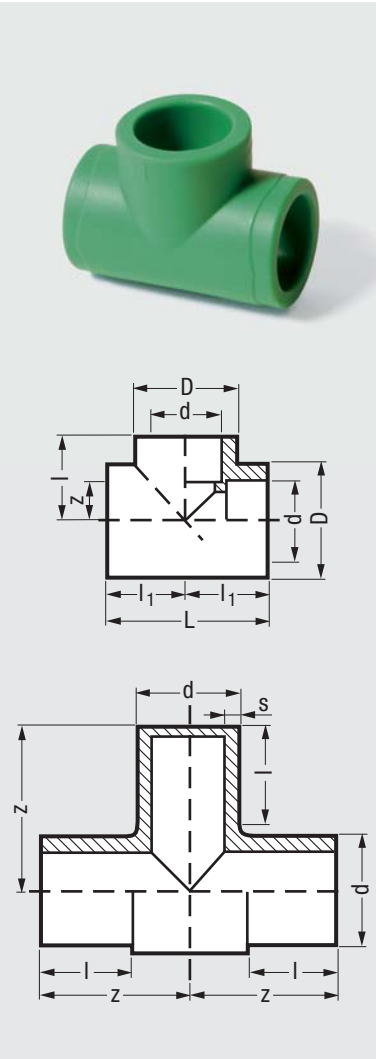

Code	d	D	l	L	l ₁	z	s	kg	Pack.
AQ13020	20	29	27	55	27	11	-	0,02	200
AQ13025	25	35	32	62	31	13	-	0,04	100
AQ13032	32	44	37	74	37	16	-	0,06	60
AQ13040	40	52	43	88	44	23	-	0,09	50
AQ13050	50	65	51	104	52	28	-	0,17	30
AQ13063	63	84	62	124	62	34	-	0,34	20
AQ13075	75	100	73	142	71	41	-	0,54	14
AQ13090	90	120	84	166	83	50	-	0,95	6
AQ130110	110	148	100	198	99	62	-	1,56	4
AQ130125	125	165	125	250	124	78	-	2,70	2
SDR 11*									
AQ130160	160	-	101	-	-	210	14,6	4,20	1
AQ130200	200	-	115	-	-	245	18,2	7,00	1
AQ130250	250	-	148	-	-	314	22,7	12,90	1

* SDR 11 jointing techniques: butt-fusion or electrofusion welding

Reducing tee

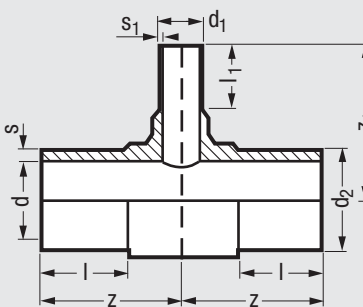
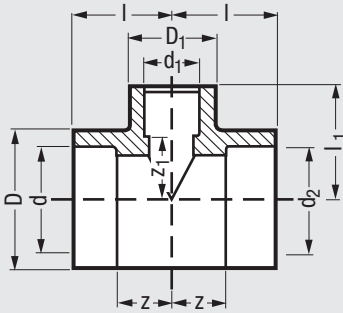

Code	d	d ₁	d ₂	D	l	z	l ₁	D ₁	z ₁	s	s ₁	kg	Pack.
AQ1302520	25	20	25	44	32	16	32	29	17	-	-	0,04	150
AQ1303220	32	20	32	43	38	20	36	34	21	-	-	0,06	90
AQ1303225	32	25	32	43	38	20	36	34	20	-	-	0,06	90
AQ1304020	40	20	40	52	44	24	39	43	24	-	-	0,08	60
AQ1304025	40	25	40	52	44	23	40	43	24	-	-	0,09	60
AQ1304032	40	32	40	52	44	23	40	43	22	-	-	0,09	60
AQ1305020	50	20	50	65	52	28	46	43	31	-	-	0,16	40
AQ1305025	50	25	50	65	52	28	46	43	30	-	-	0,16	40
AQ1305032	50	32	50	65	52	28	62	43	28	-	-	0,16	40
AQ1305040	50	40	50	65	62	39	62	65	35	-	-	0,16	30
AQ1306320	63	20	63	85	62	35	62	43	48	-	-	0,31	20
AQ1306325	63	25	63	85	62	35	62	43	46	-	-	0,31	20
AQ1306332	63	32	63	85	62	35	62	43	44	-	-	0,31	18
AQ1306340	63	40	63	85	62	39	62	85	42	-	-	0,37	20
AQ1306350	63	50	63	85	62	35	62	85	39	-	-	0,32	22
AQ1307520	75	20	75	85	71	41	71	43	57	-	-	0,51	14
AQ1307525	75	25	75	100	71	41	71	43	55	-	-	0,51	14
AQ1307532	75	32	75	100	71	41	71	43	53	-	-	0,51	14
AQ1307540	75	40	75	100	71	41	71	65	51	-	-	0,51	14
AQ1307550	75	50	75	100	71	41	71	65	48	-	-	0,51	14
AQ1307563	75	63	75	100	71	41	71	101	44	-	-	0,52	14
AQ1309063	90	63	90	120	83	50	83	120	55	-	-	0,91	6
AQ1309075	90	75	90	120	83	50	83	120	53	-	-	0,91	6
AQ13011063	110	63	110	148	99	62	99	85	71	-	-	1,53	4
AQ13011075	110	75	110	148	99	62	99	100	69	-	-	1,54	4
AQ13011090	110	90	110	148	99	62	99	120	66	-	-	1,57	4
AQ130125110	125	110	125	165	124	84	110	148	87	-	-	2,60	2
SDR 11*													
AQ130160110	160	110	160	-	101	210	88	-	210	14,6	11,4	4,98	1
AQ130200160	200	160	200	-	115	245	101	-	245	18,2	14,6	5,10	1

* SDR 11 jointing techniques: butt-fusion or electrofusion welding

Flange adaptor

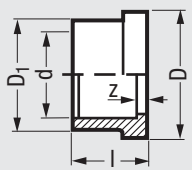
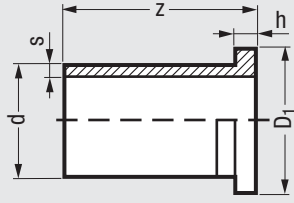
Code	d	D	l	z	h	D ₁	s	d ₄	kg	Pack.
AQ79040	40	60	29	7,4	7,8	50	-	-	0,03	160
AQ79050	50	70	33	9,7	9,5	60	-	-	0,05	160
AQ79063	63	89	40	12,9	15,5	76	-	-	0,08	100
AQ79075	75	105	37	7,5	15	89	-	-	0,13	48
AQ79090	90	125	46	9,5	19,5	109	-	-	0,25	21
AQ790110	110	158	57	13	18	132	-	-	0,38	15
AQ790125	125	162	62	13	21	146	-	-	0,48	4
SDR 11*										
AQ790160	160	-	105	180	25	212	14,6	175	1,76	1
AQ790200	200	-	125	200	32	268	18,2	232	3,22	1
AQ790250	250	-	132	207	35	320	22,7	285	4,42	1

* SDR 11 jointing techniques: butt-fusion or electrofusion welding

Cross over

Code	d	L	z	H	t	kg	Pack.
AQ28720	20	90	63	45	14	0,04	140
AQ28725	25	104	80	55	16	0,06	90
AQ28732	32	126	98	70	23	0,13	60

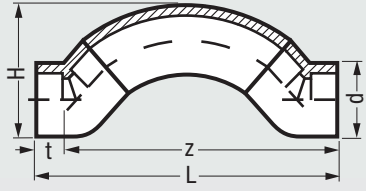
Cross over pipe

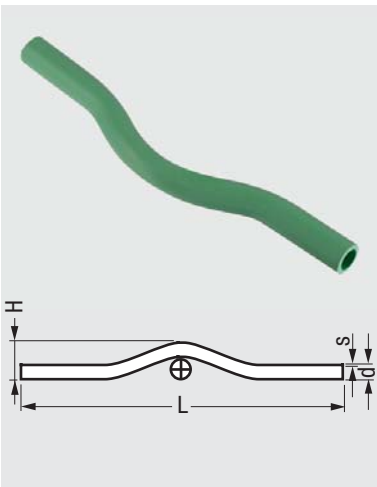

Code	d	s	H	L	kg	Pack.
AQ28520	20	3,4	53	365	0,06	1
AQ28525	25	4,2	56	370	0,09	1
AQ28532	32	5,4	68	370	0,15	1

Electrofusion socket

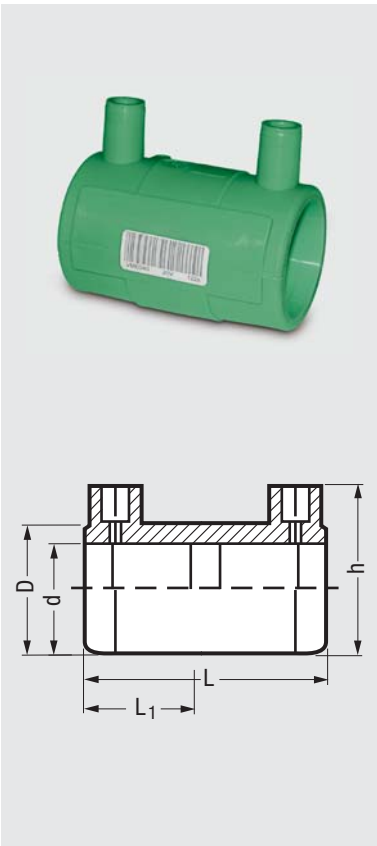

Code	d	D	L	h	L ₁	kg	Pack.
AQ27120	20	33	70	52	34	0,05	1
AQ27125	25	38	70	58	34	0,05	1
AQ27132	32	45	70	65	34	0,07	1
AQ27140	40	55	85	75	41	0,11	1
AQ27150	50	68	88	87	42	0,15	1
AQ27163	63	82	98	100	47	0,22	1
AQ27175	75	98	125	114	61	0,34	1
AQ27190	90	113	146	130	72	0,50	1
AQ271110	110	136	155	144	77	0,66	1
AQ271125	125	156	166	167	82	1,00	1
AQ271160	160	190	175	201	86	1,50	1
AQ271200	200	232	185	243	91	2,17	1
AQ271250	250	296	212	300	106	4,46	1



Transition Fittings Page

Adaptor socket (Female thread)	84
Adaptor socket (Male thread)	84
Elbow/Wall bracket 90° (Female thread)	85
Elbow bracket 90° (Female thread)	85
Elbow 90° (Male thread)	86
Union	86
Metal union with PP-R nut (Female thread)	87
Metal union with PP-R nut (Male thread)	87
Tee 90° (Female thread)	88

Adaptor socket (Female thread)

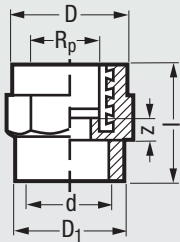

Code	d	Rp	D	D ₁	l	z	kg	Pack.
AQ270G2012	20	1/2"	35	29	41	11	0,07	200
AQ270G2034	20	3/4"	43	34	42	11	0,10	240
AQ270G2512	25	1/2"	35	34	41	11	0,07	250
AQ270G2534	25	3/4"	43	34	41	11	0,11	180
AQ270G3234	32	3/4"	43	43	44	11	0,11	170
AQ270G321	32	1"	50	43	48	12	0,15	130
AQ270G40114	40	1 1/4"	62	52	54	13	0,22	72
AQ270G50112	50	1 1/2"	69	64	57	14	0,24	75
AQ270G632	63	2"	84	79	68	19	0,49	40
AQ270G75212	75	2 1/2"	113	99	82	22	0,81	14
AQ270G903	90	3"	129	124	92	27	1,44	12
AQ270G1104	110	4"	160	151	165	27	2,15	4

Adaptor socket (Male thread)

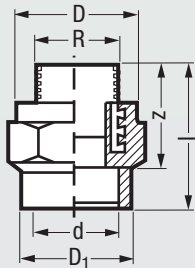

Code	d	R	D	D ₁	l	z	kg	Pack.
AQ243G2012	20	1/2"	35	29	53	40	0,08	200
AQ243G2034	20	3/4"	43	34	58	42	0,12	160
AQ243G2512	25	1/2"	35	34	53	40	0,08	160
AQ243G2534	25	3/4"	43	34	58	42	0,12	160
AQ243G3234	32	3/4"	43	43	58	42	0,13	150
AQ243G321	32	1"	50	43	66	48	0,19	100
AQ243G40114	40	1 1/4"	62	52	74	53	0,31	72
AQ243G50112	50	1 1/2"	69	64	77	54	0,35	63
AQ243G632	63	2"	84	79	92	65	0,65	28
AQ243G75212	75	2 1/2"	112	99	112	82	1,19	14
AQ243G903	90	3"	134	124	143	111	1,98	6
AQ243G1104	110	4"	169	151	161	124	2,80	4

Elbow/Wall bracket 90° (Female thread)

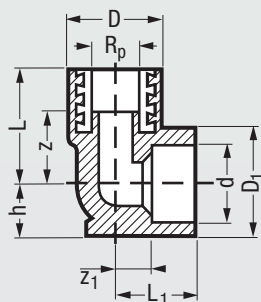

Code	d	Rp	D	L	z	h	D ₁	L ₁	z ₁	kg	Pack.
AQ472G2012	20	1/2"	35	35	21	15	29	27	11	0,08	150
AQ472G2512	25	1/2"	35	37	23	17	34	30	14	0,09	130
AQ472G2534	25	3/4"	43	43	28	22	34	35	19	0,14	100
AQ472G3234	32	3/4"	43	43	28	22	43	35	17	0,15	80
AQ472G321	32	1"	43	43	28	22	43	35	17	0,17	80

Elbow bracket 90° (Female thread)

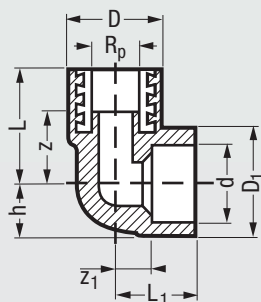

Code	d	Rp	D	L	z	h	D ₁	L ₁	z ₁	kg	Pack.
AQ090G2012	20	1/2"	35	35	21	13	29	27	11	0,08	150
AQ090G2512	25	1/2"	35	37	23	15	34	30	14	0,09	130
AQ090G2534	25	3/4"	43	43	28	20	34	35	19	0,14	100
AQ090G3234	32	3/4"	43	43	28	20	43	35	17	0,15	80
AQ090G321	32	1"	43	43	28	20	43	35	17	0,17	80

K-Aqua-Transition Fittings

Elbow 90° (Male thread)

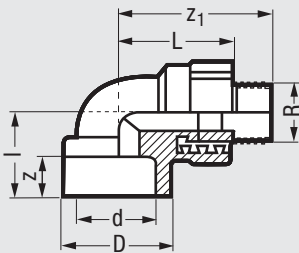

Code	d	R	D	l	z	L ₁	z ₁	kg	Pack.
AQ092G2012	20	1/2"	29	28	14	34	49	0,09	200
AQ092G2512	25	1/2"	34	32	16	38	53	0,10	180
AQ092G2534	25	3/4"	34	32	16	40	56	0,15	120
AQ092G321	32	1"	43	38	20	48	66	0,21	70

Union

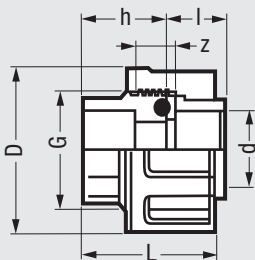

Code	d	G	D	l	L	z	l ₁	kg	Pack.
AQ330A20	20	1"	46	18	44	15	26	0,04	1
AQ330A25	25	1 1/4"	56	19	48	15	28	0,06	1
AQ330A32	32	1 1/2"	66	21	52	15	30	0,09	1
AQ330A40	40	2"	79	23	58	17	34	0,14	1
AQ330A50	50	2 1/4"	87	26	66	19	39	0,16	1
AQ330A63	63	2 3/4"	107	30	79	23	47	0,27	1

Metal union with PP-R nut (Female thread)

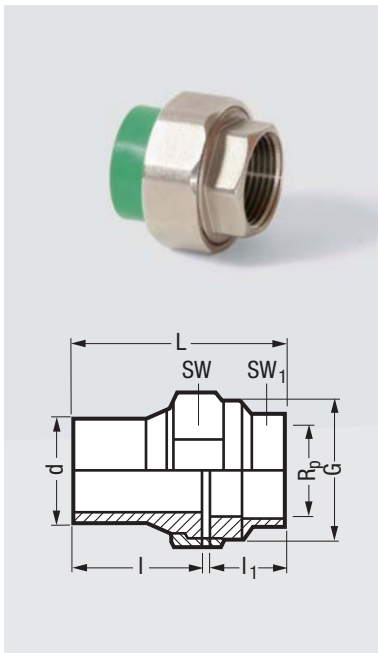

Code	d	Rp	DN	G	L	I	I ₁	SW	SW ₁	Pack.
AQ54220	20	1/2"	15	1	38	19	16	38	26	1
AQ54225	25	3/4"	20	1 3/4	43	22	18	48	32	1
AQ54232	32	1"	25	1 1/2	48	23	23	54	37	1

Metal union with PP-R nut (Male thread)

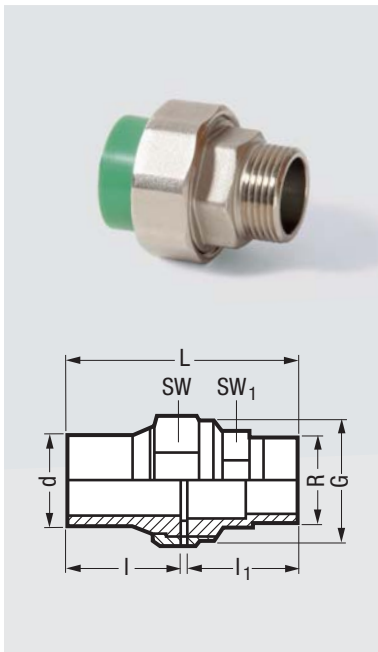

Code	d	R	DN	G	L	I	I ₁	SW	SW ₁	Pack.
AQ54720	20	1/2"	15	1	51	19	29	38	26	1
AQ54725	25	3/4"	20	1 3/4	57	22	31	48	32	1
AQ54732	32	1"	25	1 1/2	65	23	38	54	37	1

Tee 90° (Female thread)

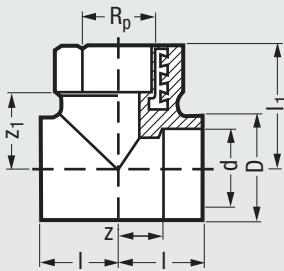

Code	d	Rp	D	l	z	l ₁	z ₁	kg	Pack.
AQ130G2012	20	1/2"	29	28	14	33	20	0,08	180
AQ130G2512	25	1/2"	35	31	16	37	24	0,09	100
AQ130G2534	25	3/4"	34	32	16	40	25	0,13	100
AQ130G3234	32	3/4"	43	38	20	45	30	0,15	60
AQ130G321	32	1"	43	38	20	48	30	0,20	60



Weld-in saddles

Page

Weld-in saddle	90
Weld-in saddle (Female thread)	90
Weld-in saddle (Male thread)	91

K-Aqua-Weld-in saddle

Weld-in saddle

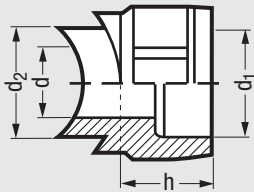

Code	d	d ₁	d ₂	h	Pack.
AQ130S406320	40 - 63	20	25	29	150
AQ130S406325	40 - 63	25	25	29	90
AQ130S406332	40 - 63	32	25	29	90
AQ130S7512525	75 - 125	25	25	29	60
AQ130S7512532	75 - 125	32	32	35	60
AQ130S7512540	75 - 125	40	40	38	60
AQ130S16025025	160 - 250	25	25	29	40
AQ130S16025032	160 - 250	32	32	35	40
AQ130S16025040	160 - 250	40	40	38	40
AQ130S16025050	160 - 250	50	50	39	30
AQ130S16025063	160 - 250	63	63	45	20

Weld-in saddle (Female thread)

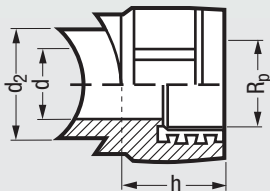

Code	d	R _p	-d ₂	h	Pack.
AQ270S406312	40 - 63	1/2"	25	43	150
AQ270S406334	40 - 63	3/4"	32	50	90
AQ270S7512512	75 - 125	1/2"	25	43	90
AQ270S7512534	75 - 125	3/4"	32	50	60

Weld-in saddle (Male thread)

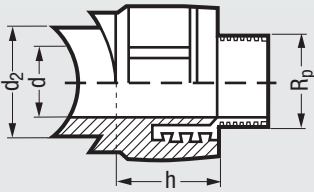

Code	d	Rp	-d ₂	h	Pack.
AQ243S406312	40 - 63	1/2"	25	43	150
AQ243S406334	40 - 63	3/4"	32	50	90
AQ243S7512512	75 - 125	1/2"	25	43	90
AQ243S7512534	75 - 125	3/4"	32	50	60



Valves

Page

Concealed valve chrome heavy part	94
Concealed valve chrome light part	94
Straight seat valve green handle	94
Elongation pieces	94
Ball valve	95
Metal ball valve with PP-R nut	96
Tee 90° (Female thread) for internal valve	96

Concealed valve (only upper part) chrome heavy part

	Code	Dimension G	kg	Pack.
	AQ5993	3/4"	0,31	1

Concealed valve (only upper part) chrome light part

	Code	Dimension G	kg	Pack.
	AQ5992	3/4"	0,21	1

Straight seat valve (only upper part) green handle

	Code	Dimension G	kg	Pack.
	AQ5991	3/4"	0,12	1

Elongation pieces

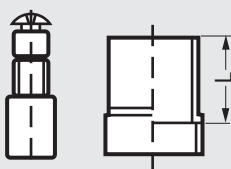
 	Code	L	kg	Pack.
	AQ599E	30	0,05	1

PP-R Ball valve (Ball in brass, chromium plated)

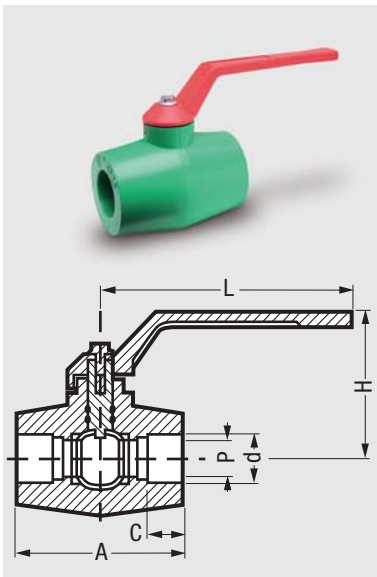

Code	d	A	C	H	L	P
AQ85020	20	67,5	14,5	60	102	15
AQ85025	25	70,5	16	60	102	15
AQ85032	32	79,5	18	63	102	20
AQ85040	40	94	20,5	78	119,5	25
AQ85050	50	109	23,5	83	119,5	32
AQ85063	63	130	27,5	103	146	40

PP-R Ball valve (Ball in PP)

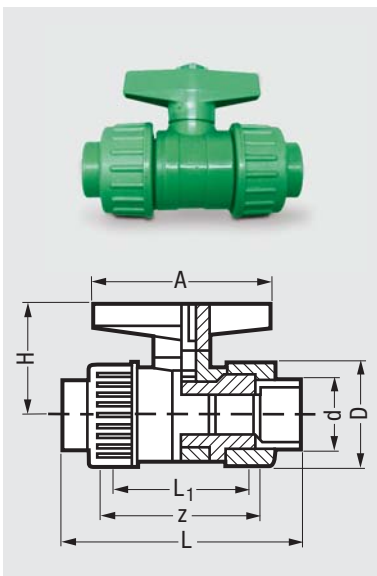

Code	d	D	L	z	H	A	L ₁	kg	Pack.
AQ85220	20	46	98	70	51	68	63	0,11	1
AQ85225	25	56	113	82	61	78	75	0,19	1
AQ85232	32	66	121	87	70	88	79	0,28	1
AQ85240	40	79	138	98	81	98	91	0,44	1
AQ85250	50	87	148	101	90	108	95	0,54	1
AQ85263	63	107	175	121	110	118	115	0,93	1

Metal ball valve with PP-R nut

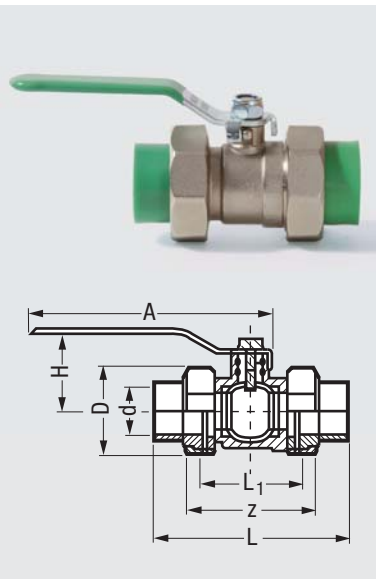

Code	d	D	L	z	H	A	L ₁	kg	Pack.
AQ85325	25	45	91	54	41	102	43	0,251	1
AQ85332	32	52	96	56	51	122	47	0,325	1

Tee 90° (Female thread) for internal valve

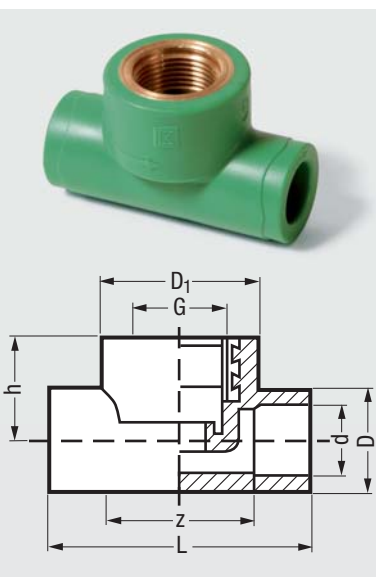

Code	d	G	D	L	D ₁	z	h	kg	Pack.
AQ599A2034	20	3/4"	33	80	45	46	33	0,11	100
AQ599A2534	25	3/4"	36	80	45	43	33	0,12	80
AQ599A3234	32	3/4"	43	75	45	39	33	0,14	80



Accessories

Page

**Backing flange PP-Steel
for socket fusion system (SF)
or butt fusion system (BF)**

98

Flat gasket

98 - 99

Pipe clamps

99

Backing flange PP-Steel for socket fusion system (SF) or butt fusion system (BF)

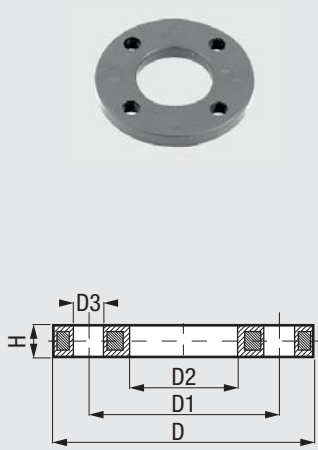

Code	d	D	D ₁	D ₂	D ₃	H	System	kg	Pack.
AQ75040	40	140	100	51	18	16	SF/BF	0,62	20
AQ75050	50	150	110	62	18	18	SF/BF	0,82	17
AQ75063	63	165	125	78	18	18	SF/BF	0,94	15
AQ75075	75	185	145	92	18	18	SF/BF	1,35	11
AQ75090	90	200	160	110	18	20	SF	1,39	13
AQ750110	110	220	180	133	18	20	SF	1,41	13
AQ750125	125	250	210	150	18	20	SF	1,41	12
AQ750160	160	285	240	178	22	24	BF	3,60	1
AQ750200	200	340	295	235	22	27	BF	5,20	1
AQ750250	250	395	350	288	22	30	BF	6,63	1

Flat gasket



Code	d	Pack.
AQ71440	40	1
AQ71450	50	1
AQ71463	63	1
AQ71475	75	1
AQ71490	90	1
AQ714110	110	1
AQ714125	125	1
AQ714160	160	1
AQ714200	200	1
AQ714250	250	1

Flat gasket for unions PP-R

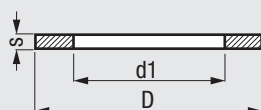

Code	d	R/Rp	Nut thread	D	d ₁	s	Pack.
AQ490F20	20	1/2"	G 3/4"	27	20	3	1
AQ490F25	25	3/4"	G 1"	35	25	3	1
AQ490F32	32	1"	G 1 1/4"	38	28	3	1

Pipe clamps



Code	d	kg	Pack.
AQ50020	20	0,06	100
AQ50025	25	0,06	100
AQ50032	32	0,07	75
AQ50040	40	0,08	50
AQ50050	50	0,08	50
AQ50063	63	0,13	50
AQ50075	75	0,20	25
AQ50090	90	0,21	25
AQ500110	110	0,24	25
AQ500125	125	0,30	25
AQ500160	160	0,35	25
AQ500200	200	0,37	10
AQ500250	250	0,52	10

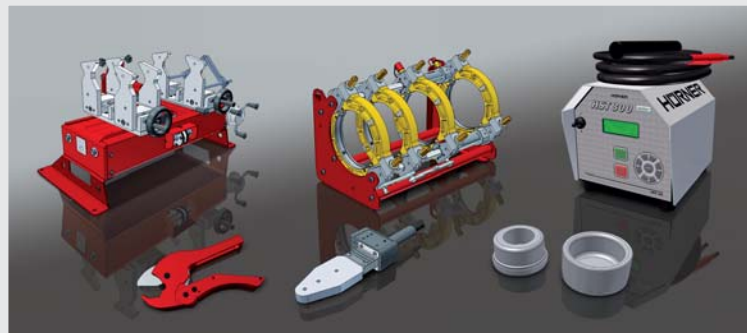

Tools

Page

Pipe cutter 20-40	102
Pipe cutter 50-125	102
Pipe scraper	102
Hand welding machine 20-63	102
Hand welding machine 20-32	102
Hand welding machine 50-125	102
Welding tool	103
Welding tool for weld in saddles	103
Drilling tool for weld in saddle	104
Welding tool for repairing plug	104
Repairing plug	104
Welding machine 50-125	104
Butt welding machine 90-250	105
Electrofusion machine	105

Pipe cutter 20-40

	Code	Pack.
	AQ97040	1

Pipe cutter 50-125

	Code	Pack.
	AQ975125	1

Pipe scraper

	Code	Pack.
	AQ974	1

Hand welding machine 20-63 (complete set)

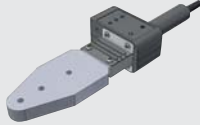
	Code	Pack.
	AQ98063	1

Hand welding machine 20-32 (complete set)

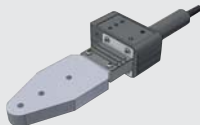
	Code	Pack.
	AQ98032	1

Hand welding machine (only mirror) 50-125

	Code	Pack.
	AQ991125	1

Welding tool

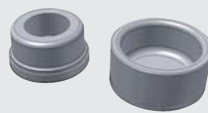

Code	d	Pack.
AQ98220	20	1
AQ98225	25	1
AQ98232	32	1
AQ98240	40	1
AQ98250	50	1
AQ98263	63	1
AQ98275	75	1
AQ98290	90	1
AQ982110	110	1
AQ982125	125	1

Welding tool for weld in saddles

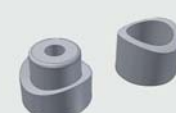

Code	d	Pack.
AQ98504006325	40-63x25	1
AQ98507512525	75-125x25	1
AQ98507512532	75-125x32	1
AQ98507512540	75-125x40	1
AQ98516025025	160-250x25	1
AQ98516025032	160-250x32	1
AQ98516025040	160-250x40	1
AQ98516025050	160-250x50	1
AQ98516025063	160-250x63	1

Drilling tool for weld in saddle



Code	Pack.
AQ98625	1
AQ98632	1
AQ98640	1
AQ98650	1
AQ98663	1

Welding tool for repairing plug



Code	d	Pack.
AQ9837	7	1
AQ98311	11	1

Repairing plug



Code	d	Pack.
AQ5937	7	1
AQ59311	11	1

Welding machine 50-125 (complete set)

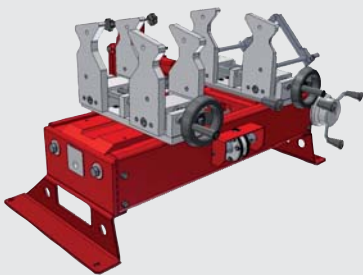

Code	Pack.
AQ988125	1

Butt welding machine 90-250

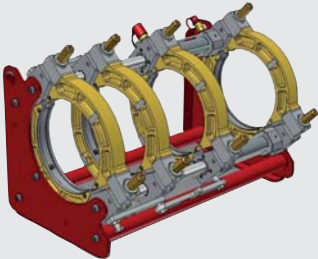
	Code	Pack.
	AQ989250	1

Electrofusion machine

	Code	Pack.
	AQ990	1

1. General

The supply of our goods and services are subject to the following terms and conditions provided that the Customer is a person acting in the course of his business or is a public authority. Any terms and conditions of the Customer which conflict with or deviate from the following shall not apply except where we have expressly agreed to the same in writing. Our unconditional supply of goods and services or receipt of payment by us shall not be construed as acceptance of conflicting terms and conditions.

These terms and conditions shall govern all future purchase orders placed by the Customer. The goods and services supplied by us are in conformity with the laws and standards in force in Germany. We do not warrant conformity with the laws and standards of other countries (see clause 9). Insofar as is necessary for the handling of our business we are entitled to store and process the Customer's data in digital form to the extent permitted by data protection laws (in particular §28 of the German Data Protection Act).

2. Contractual Representations

Our quotations are without obligation in terms of price, quantity, delivery term and availability. Our order acknowledgement in text form is definitive in terms of confirming acceptance of your order, the scope of delivery and delivery date.

3. Prices, Payment Terms, Set Off

Except where otherwise agreed our prices are subject to the price list valid at the date of the contract. They are ex works (EXW Incoterms 2010) and do not include packing, freight, customs duties, ancillary import charges, insurance and VAT. VAT shall be charged at the rate current at the date of performance. All items are subject to a packing charge of 3% of the list price. Assembly, installation or any other services will be charged on a time and material basis.

Where the delivery or performance date is more than 3 months after the contract date we are entitled upon timely notification to the Customer and prior to delivery or performance to adjust the price in such a manner as is necessitated by any general price development beyond our control (e.g. exchange rate fluctuations, currency regulations, customs duties changes, increases in material and production costs) or by changes of suppliers. For supplies of goods or services within three months from the contract date the contract price shall apply in any event. In relation to framework agreements with a price clause the three month period shall begin to run upon the effective date of the agreement. In relation to framework agreements with a price clause the three month period shall begin to run upon the effective date of the agreement. Except where otherwise agreed the Customer shall remit payment of the agreed price without deduction within 30 days of the date of invoice. Upon expiry of the payment term the customer shall be deemed in default of payment. Payment remitted within 10 days of the invoice date are subject to a 3% discount. Cheques and bills of exchange will not be accepted as a means of payment.

The Customer may only set off undisputed counterclaims or counterclaims against which we have no further recourse to appeal; his rights under warranty will not be limited by the aforesaid. The Customer shall only be entitled to rights of retention in so far as these are based on the same legal transaction.

4. Delivery Date

The commencement of the delivery term quoted shall be subject to clarification of all technical matters and proper and timely performance by the Customer of his obligations.

Where we fail to deliver upon an agreed delivery date and such failure is caused by an act or omission on our part the Customer shall grant us an extension in writing of not less than 2 weeks. Where upon the expiry of the grace period, delivery is still not forthcoming and the Customer desires to rescind the contract or demand damages in lieu of performance, the Customer shall prior thereto set a final and reasonable deadline in writing expressly indicating his intention. The Customer is obliged at our request to declare within a reasonable period whether he shall rescind the contract due to the delay in delivery and/or demand damages in lieu of performance or insist upon performance.

Where assembly, installation or commissioning is delayed due to reasons for which we are not responsible the Customer shall bear the reasonable cost of any waiting time and additional travel expenses incurred by our service personnel.

5. Shipment, Transfer of Risk

We supply our goods and services „ex works“(EXW Incoterms 2010). The risk of loss, destruction or damage passes to the Customer upon loading at our warehouse or when the goods cannot or are not to be shipped upon notification of their readiness for shipment. This shall also apply where we deliver by installment or where we have assumed other duties to include without limitation transportation or to supply to the delivery location or assembly of the goods.

Where we instructed to supply to the delivery location, we reserve the right to select the transport route and the mode of transport. We shall select the packaging, protection aids and / or means of transportation on the basis of our experience at the expense of the Customer. Extra costs incurred by special shipping requirements of the Customer shall be for the account of the Customer. The same applies to increases in freight charges that occur after the contract is concluded, any additional costs for re-routing, warehouse charges etc. except where delivery carriage paid is agreed.

Supply of goods or services by installment is permitted except where unreasonable for the Customer.

In relation to make and hold orders approximately the same quantities shall be called off each month except where otherwise agreed in writing. The entire order quantity shall be deemed called off one month after the expiration of the call off deadline, or in the absence thereof twelve (12) months after the contract date. Where the Customer fails to assign goods ordered to a certain delivery within one month after the expiry of the deadline for such assignment, or in the absence of an agreed deadline, within one month of our request for such assignment, we reserve the right to assign the goods at our discretion and deliver the same.

Excess or short deliveries are permitted insofar as they are within the limits which are customary in the trade.

6. Sub-Contractors

We are entitled to use sub-contractors for performance of our contractual obligations.

7. Act of God

In the event of act of god we are entitled to suspend performance of our obligation to deliver. Where there is a considerable change in the circumstances prevalent at the formation of the contract, we reserve the right to rescind the contract. The same shall apply in relation to shortages of energy or raw materials, strikes, governmental decrees, disruption of operations or infrastructure or where, for the above reasons, a sub-supplier fails to supply us properly, on time or at all.

8. Retention of Title

Goods sold shall remain our property until payment of all claims under the business relationship has been received from the Customer ("Reserved Goods").

If the Customer works or processes the Reserved Goods our reservation of title shall be extended to cover the whole of the new article. In the case of processing, combining or mixing with external goods by the Customer we shall acquire title in the fraction that corresponds to the invoice value of our goods to that of the other objects used by the Customer at the time the processing, combining or mixing took place.

If the Reserved Goods are combined or mixed with a principle good belonging to the Customer, the latter hereby assigns in addition his rights in the new good to us. If the Customer combines or mixes the Reserved Goods with a principle good belonging to a third party against payment, he hereby assigns his claims for payment against the third party to us.

The Customer may resell Reserved Goods in the framework of due business activities. If the Customer sells such goods without receiving the full purchase price in advance or contemporaneously with the surrender of the item purchased, he shall agree a reservation of title with his customers in accordance with these conditions. The Customer hereby assigns to us his claims under this resale and the rights under the reservation of title agreed. He agrees at our request to notify the assignment to Customers and to provide us with the information required to claim our rights against the Customers and to hand over documents. Irrespective of the assignment the Customer shall only be authorised to collect payments under the resale as long as he complies duly with his obligations to us.

If the value of the securities provided to us exceeds our claims by more than 10 per cent, we undertake to release securities of our choice on demand by the Customer.

In the event that the above retention of title clauses are void or unenforceable according to the law of the state/country in which the goods are situated, the collateral security which corresponds to the retention of title in that state/country is deemed to be agreed.

9. Customer's Rights in the case of Defects

The goods supplied by us correspond to the German regulations and standards currently in force. We give no guarantee that the goods comply with other national regulations. Where the goods are to be put into operation overseas it is the responsibility of the Customer to ensure that the goods are in conformity with the relevant legal requirements and standards and where required to make appropriate adaptations. The Customer shall not be entitled to make a claim based on defective delivery or performance where the reduced value or merchantability of the goods delivered or services supplied is nominal.

Where the goods delivered by us are defective and the Customer has notified us of the same in writing not later than 28 days after the delivery date we shall at our option deliver a replacement or remedy the defect. The Customer shall grant us a reasonable period of not less than 15 working days to carry out the same.

The Customer is entitled to demand reimbursement of the costs incurred by reason of the replacement delivery or remedying of the defect insofar as such costs are not increased due to the subsequent transportation of the goods delivered to a location other than the original shipment location unless the purpose for which the goods are intended requires the same.

In the event that we are not in a position to remedy the defect or deliver a replacement the Customer is entitled to rescind the contract or to demand a reasonable reduction in the purchase price. Rescission of the contract is only permissible where the Customer prior thereto sets a final and reasonable deadline in writing expressly indicating his intention.

The Customer shall retain a statutory right or recourse against us insofar as the Customer has not agreed terms with its customer which exceed the statutory liability for defects.

10. Liability

Except where otherwise provided below any claim of the Customer for damages other than those claims set out in § 9 aforesaid are hereby excluded irrespective of the legal grounds upon which it is based. Accordingly we do not accept liability for any damage not incurred by the goods themselves nor do we accept any liability for loss of profit or any other pecuniary loss suffered by the Customer. To the extent that our contractual liability is excluded or limited, such exclusion or limitation shall apply in relation to the personal liability of employees, representatives and vicarious agents.

The aforesaid limitation of liability shall not apply where the damage incurred has been caused by wilful default, by gross negligence or breach of guarantee, where personal injury has been suffered or where damages are claimed under the product liability act.

Where we are in negligent breach of a material term of the contract our liability to compensate damage to property shall be limited to such loss as was typically foreseeable at the time the contract was made. A material term of the contract shall be any term which places the Customer in the legal position provided for under the contract in terms of its content and purpose and any term which must be complied with in order to ensure proper performance of the contract and upon the performance of which the Customer relied or could be reasonably expected to rely.

Any other liability in damages is hereby excluded.

Any assignment of the Customer's claims provided for in § 9 and 10 above is not permitted, insofar as this prohibition is permissible at law.

11. Limitation

The limitation period for claims based on the supply of defective goods and services (§9) as well as for claims for damages (§10) is one year from the date of delivery. The limitation period aforesaid shall not apply in relation to claims based on wilful default, gross recklessness, breach of guarantee or to personal injury claims and to claims under product liability laws (§9 sub-para. 2).

The limitation period aforesaid shall further not apply where longer limitation periods are prescribed by law including without limitation claims relating to buildings, defects in construction and rights of recourse.

12. Product Description

A description of all of our goods is set out in our „General Technical Data Sheets“, which will be sent to the Customer on request. It is the responsibility of the Customer to test our goods and services as to their suitability for the purpose intended

13. Jurisdiction, Choice of Law

For Customers whose principle place of business is situated in the European Union all disputes arising out of these terms and conditions shall be resolved before the courts with jurisdiction located at our principle place of business. We reserve the right to sue the Customer at its principle place of business.

For Customers whose principle place of business is situated outside the European Union all disputes arising out of these terms and conditions shall be finally settled in accordance with the Rules of the German Institution of Arbitration e.V. (DIS) without recourse to the ordinary courts of law. The place of arbitration shall be Frankfurt am Main, Germany. The laws of the Federal Republic of Germany shall govern all the legal relationships between us and the Customer.



Kessel Wassertechnologie GmbH

Auweg 3 · 35647 Waldsolms-Brandoberndorf · Germany

www.k-aqua.de · info@k-aqua.de

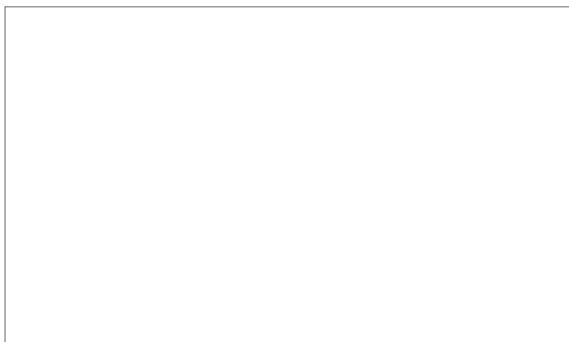

Rights reserved for technical changes.

Edition: September 2016



Made in Germany