

CIRCULATION LOOP MIXERS

JRGUMAT Thermoblending Valves

The JRGUMAT 3400 thermoblending valve is designed to provide a stable working temperature for circulating loop systems.

Under current New Zealand legislation, loop systems must circulate hot water at not less than 60°C. This ensures Legionella bacteria are killed. To achieve this the boiler must heat water to 70°C+.

By using JRGUMAT 3400 the high temperature circulating water limits scale buildup in pipes, connections, valves etc plus it actually **reduces** hot water use - the higher the inlet water temperature the more cold water is needed to achieve the ideal bathing temperature. Thus less hot water is actually used to achieve the desired mixed water temperature.



← Optimal operating conditions within shaded area

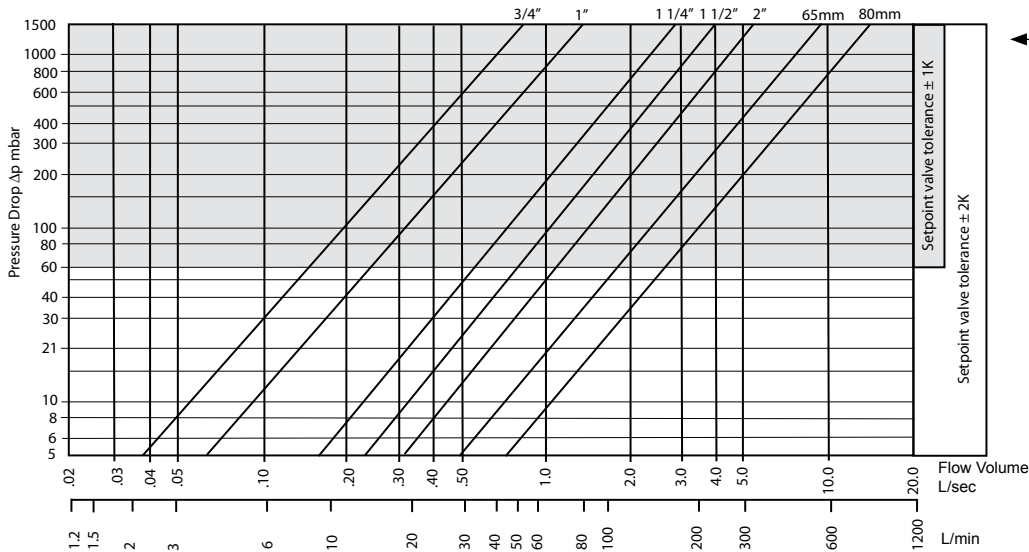

Sizing Your JRGUMAT

The size of the JRGUMAT 3400 valve will generally coincide with the designed pipe size but will also depend on many variables including:

- type and flow requirements of outlet fixture
- static pressure
- coefficient of simultaneous use
- type of pipe system used

The pipe layout should be designed by a suitably qualified person who takes all these facts into consideration.

Product Code	Size	A	B	C	D
JRG340019X-55	3/4"	40	40	60	49
JRG340025X-55	1"	43	43	67	51
JRG340032X-55	1 1/4"	52	52	78	75
JRG340040X-55	1 1/2"	58	58	92	77
JRG340050X-55	2"	70	70	110	85
JRG341065X-55	65mm	145	145	145	121
JRG341080X-55	80mm	155	155	155	127

Specification

Maximum inlet temperature:

- HW - 90°C
- CW - 20°C

Minimum temperature differential:

- 10°C between inlet HW and outlet MW

Pressure range:

- 1 to 5 Bar

Pressure differential:

- 15% between HW & CW

- Valve adjustable from 45 - 65°C (adjust on site to 60°C)

- Ensure circulation loop system is designed with all necessary check valves, isolators, pumps etc as per circulation drawings enclosed.

- All pipework must be thoroughly flushed prior to JRGUMAT installation.

- JRGUMAT valves must be installed a minimum of 1m from heating source

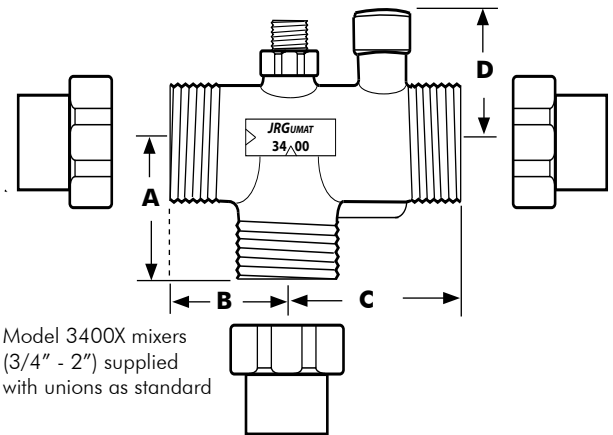

Model 3400X mixers (3/4" - 2") supplied with unions as standard

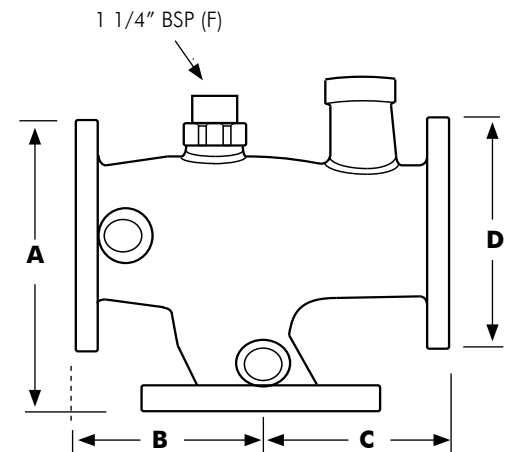

Model 3410X mixers (65 & 80mm) supplied with recirculation union as standard. Supplied with 4 hole DIN flanges

CIRCULATION LOOP MIXERS (cont)

Basic Circulation Loop

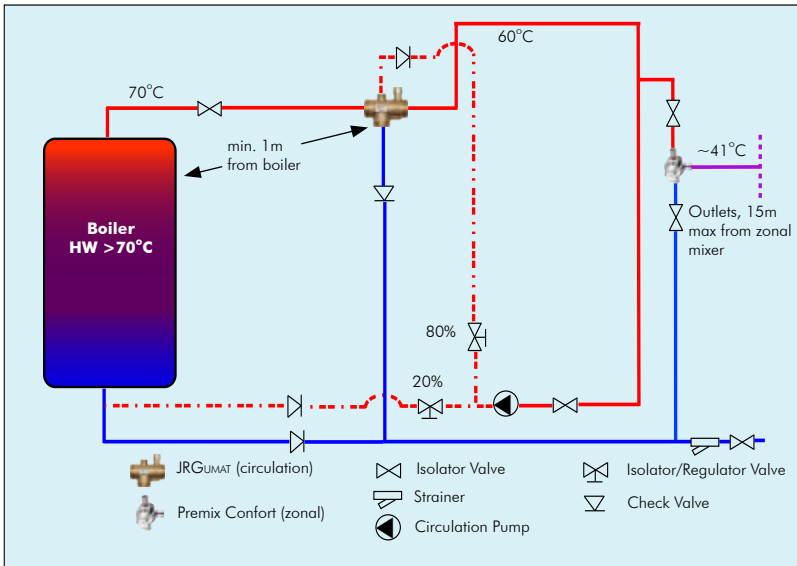

MECHANICAL REGULATION

Using *JRGUMAT 3400* with a circulation loop system and mechanical regulation on the recirculation loop. Suitable where hot water supply temperature is stable.

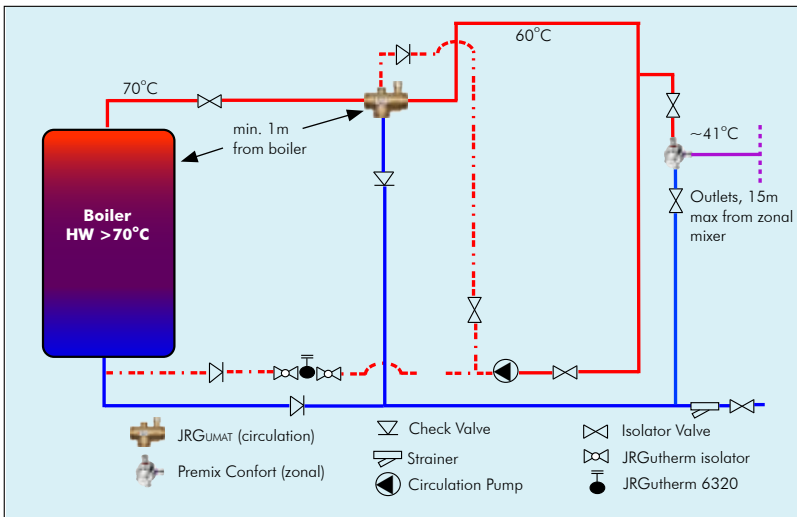

THERMAL REGULATION

Using *JRGUMAT 3400* with a circulation loop system and thermal regulation on the recirculation loop with *JRGUTHERM 6320* flow regulator - see below. Suitable where hot water supply temperature is variable due to seasonal conditions or alternative energy sources e.g. wood fired, solar etc

Note: More complex circulation loop drawings shown on www.macdonaldindustries.co.nz

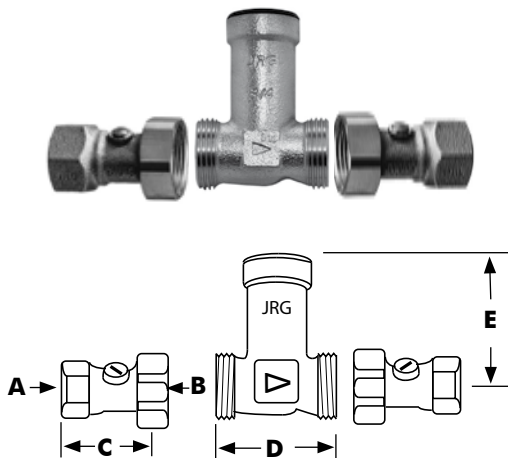

Product Code	A	B	C	D	E
JRG632012X	1/2"	3/4"	55	60	64
JRG632019X	3/4"	1"	55	60	64

JRGUTHERM 6320 FLOW REGULATOR

Automatically adjusts return flow depending on temperature of circulation loop. When loop temperature drops (static flow) valve opens allowing water to return to boiler for re-heating thus maintaining loop temperature at desired setting.

Valve pre-set to 57°C but adjustable from 36 - 63°C

Supplied complete with 2 x Model 8339 isolating unions when specified with suffix "X"